

DESCRIPTION

AM072MX-QF-R is a GaAs MESFET with a total gate width of 7.2mm. It is RoHS compliant (Denoted by -R). The AM072MX-QF-R is designed for high power microwave applications, operating up to 6 GHz. The QF series is in a plastic package with straight leads in a drop-in mounting style. The bottom of the package serves simultaneously as DC ground, RF ground, and thermal path.

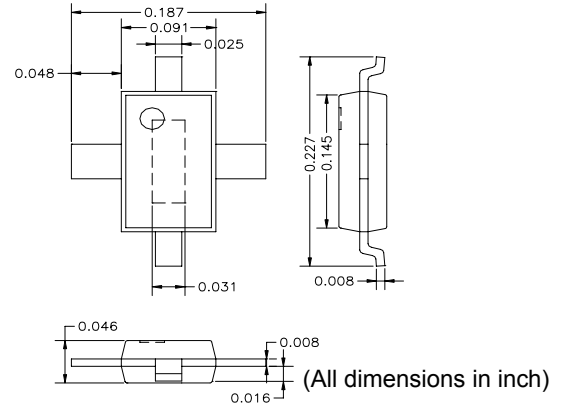

FEATURES

- High Frequency Operation up to 6 GHz
- High Gain and High Power, $P_{1dB}=34\text{dBm}$ @3.5GHz
- Plastic Package for Low Cost
- 3 Heat Sink Paths for Effective Heat Removal

APPLICATIONS

- Wireless Local Loop Network
- PCS Base Stations
- WLAN, Repeaters & HYPERLAN
- C-Band VSAT

RF PERFORMANCE @ 3.5 GHz, ($V_{ds} = 7\text{V}$, $I_{ds} = 0.5 I_{dss}$)

Parameters	MIN	TYP
P_{1dB} * (dBm)	33	34
Eff @ P_{1dB}	38%	42%
Small Signal Gain (dB)	9.5	11
IP3 (dBm)	42	44

* Power typically remains the same as frequency changes.

ABSOLUTE MAXIMUM RATING

Parameters	Symbol	Rating
Drain-Source Voltage (V)	V_{ds}	9
Gate-Source Voltage (V)	V_{gs}	-5
Drain Current (mA)	I_{ds}	2280
Continuous Dissipation At Room Temp. (W)	P_t	13
Operating Temp. ($^{\circ}\text{C}$)	T_A	-55 to +85
Max. Channel Temp. ($^{\circ}\text{C}$)	T_{ch}	+175

DC PARAMETERS

Parameters	Conditions	MIN	TYP	MAX
Saturation Current I_{dss} (mA)	$V_{ds} = 3\text{V}$ $V_{gs} = 0\text{V}$	1320	1680	2280
Pinch-off Voltage V_p (V)	$V_{ds} = 3\text{V}$ $I_{ds} = 2.5\% I_{dss}$	-2.6	-2	-1.2
Drain to Gate Breakdown Voltage BV_{gd} (V)	$I_{dg} = 1\text{mA/mm}$	11	15	
Drain to Source Voltage V_{ds} (V)	Mounted on Heat Sink		7	8
Thermal Resistance ($^{\circ}\text{C/W}$)		11.3		

S-Parameters for AM072MX-QF-R @ 7V / 0.5 I_{dss} (s2p file downloadable from the web)

Freq (MHz)	MAG (S11)	ANG(S11)	MAG (S21)	ANG(S21)	MAG (S12)	ANG(S12)	MAG (S22)	ANG(S22)
1000	0.911	-169.617	2.708	85.535	0.029	9.558	0.712	179.969
2000	0.917	174.984	1.427	64.609	0.03	8.901	0.724	177.039
3000	0.925	167.477	0.956	46.918	0.029	9.474	0.743	168.773
4000	0.932	160.758	0.712	31.729	0.026	17.803	0.76	160.938
5000	0.941	152.586	0.571	17.386	0.027	30.279	0.78	154.516
6000	0.949	143.766	0.491	3.208	0.042	37.422	0.8	145.242
7000	0.938	133.242	0.418	-10.43	0.048	25.7	0.814	139.281
8000	0.939	122.379	0.358	-22.995	0.051	19.929	0.83	133.633

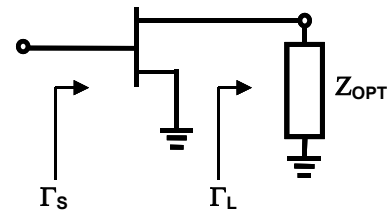
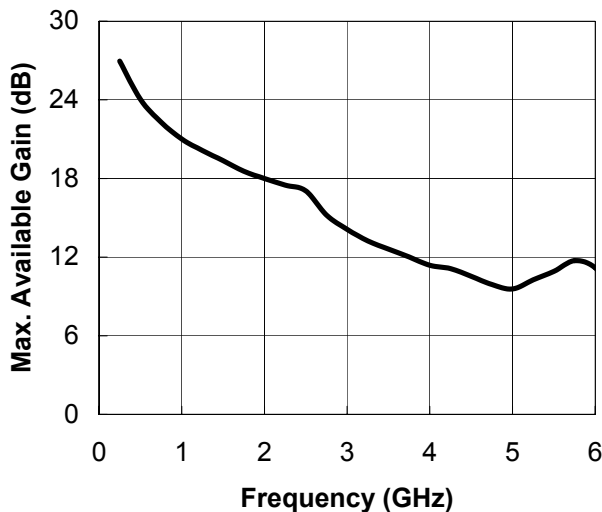

OPTIMUM LOADS

Freq GHz	Γ _s MAG	Γ _s ANG	Γ _L MAG	Γ _L ANG
1	0.988	-168.78	0.750	-173.62
2	0.988	173.67	0.756	-166.87
3	0.987	162.05	0.765	-159.45
4	0.986	151.43	0.774	-151.08
5	0.985	140.61	0.783	-141.54
6	0.984	128.96	0.790	-130.56

Specifications subject to change without notice.