

CMOS PA For Wireless Applications¹

Amin K. Ezzeddine and Ho. C. Huang

AMCOM Communications, Inc.

22300 Comsat Drive, Clarksburg, Maryland 20871, USA

Tel: 301-353-8400 email: amin@amcomusa.com

Robert S. Howell, Harvey C. Nathanson
and Nicholas G. Paraskevopoulos

Northrop Grumman Corporation, Electronics Systems,
Baltimore, Maryland, USA

¹This work is partially supported by DARPA, contract No. N66001-04-C-8034

Presentation Outline

- Why do we need a CMOS high-voltage device?
- Brief description of the HIFET configuration
- 0.18 μm Low-voltage operation CMOS process description & HIFET device design
- RF data results of HiFET CMOS
- Conclusion

Why High Voltage Device?

- Mitigate low breakdown, low bias voltage in semiconductors devices such as: GaAs FET, pHEMT, InP, sub-micron CMOS.
- Simpler matching for high-power applications
- Higher power and broadband matching
- Some applications require high voltage

Motivation for Current Work

- Efforts are currently being directed towards integrating the RF PA with TX/RX and BB circuits
- BiCMOS process is a preferred process for integration
- CMOS devices are difficult to match for any significant amount of power
- Si substrate RF losses are significant

What is HIFET?

- HIFET is an innovative power combining technique connecting identical FETs RF & DC in series.
- HIFET has high voltage and high impedance.
- Output impedance could be raised to near 50Ω .
- HIFET enjoys a bonus gain of $10 \log N$ dB.
- HIFET concept applies to any FET device such as MESFET, HEMT, CMOS, LDMOS, GaN, SiC etc.

HIFET Voltage Waveforms

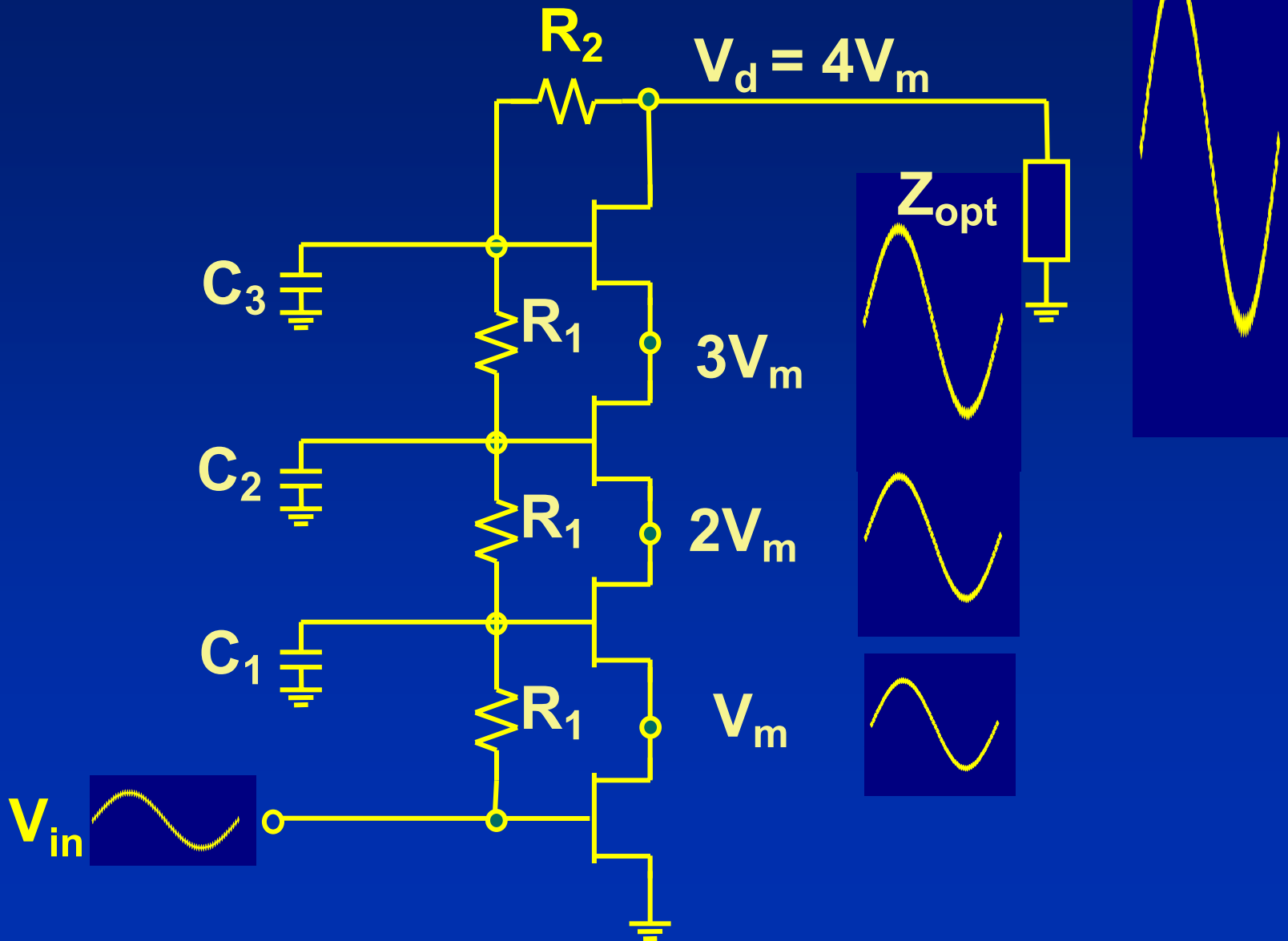

Impedance Optimization of Common Gate FET

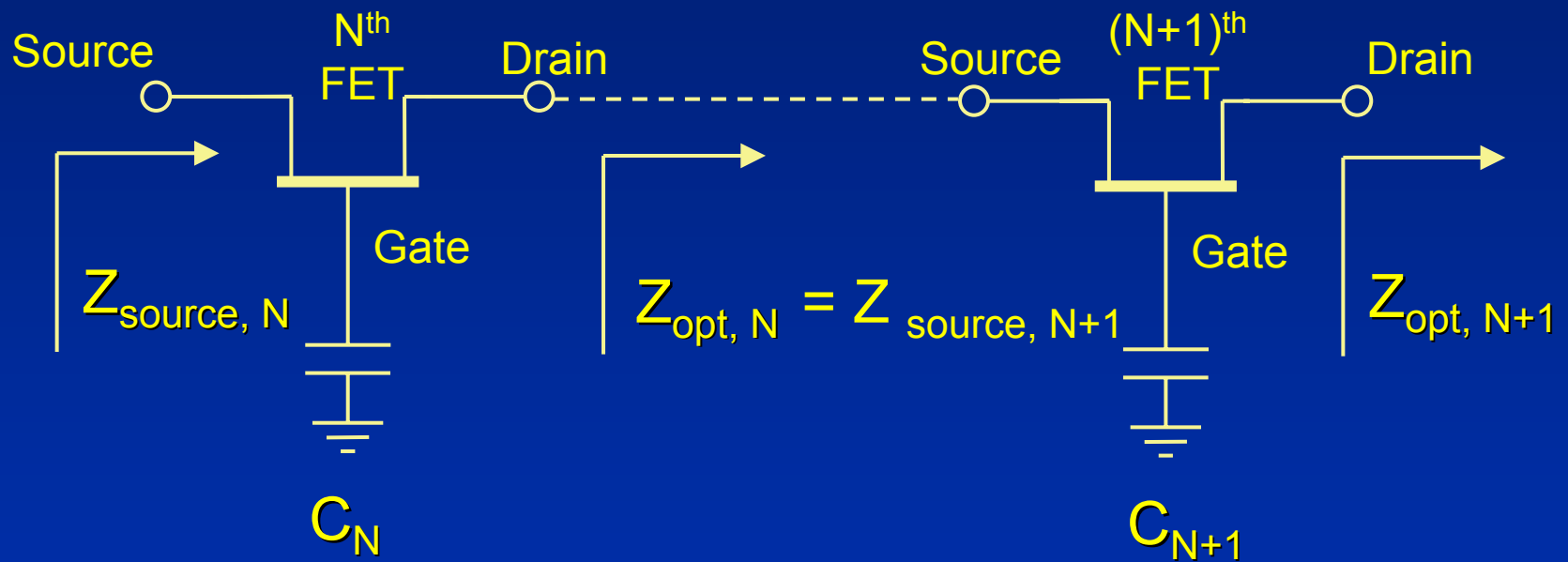

$$Z_{\text{source}, N} \cong 1/g_m (C_{\text{gs}} + C_N) / C_N$$

g_m is FET transconductance

C_{gs} is FET gate-to-source capacitance

HiHET Configuration Features

- Equivalent performance to a single device with high voltage (i.e. Ideal power combiner)
- High voltage bias: $V_{dd} = V_{ds} \times N$
- Lower Current by $1/N$ factor compared to regular FET with equivalent periphery. (i.e. Scaled I-V characteristics)
- Higher optimum output impedance by N^2 factor
- Higher input impedance
- Higher gain by factor of N
- Broadband matching
- Simple & compact configuration
- Concept applicable to any FET technology

I-V Characteristics of a 4 x 3mm GaAs MESFET HIFET

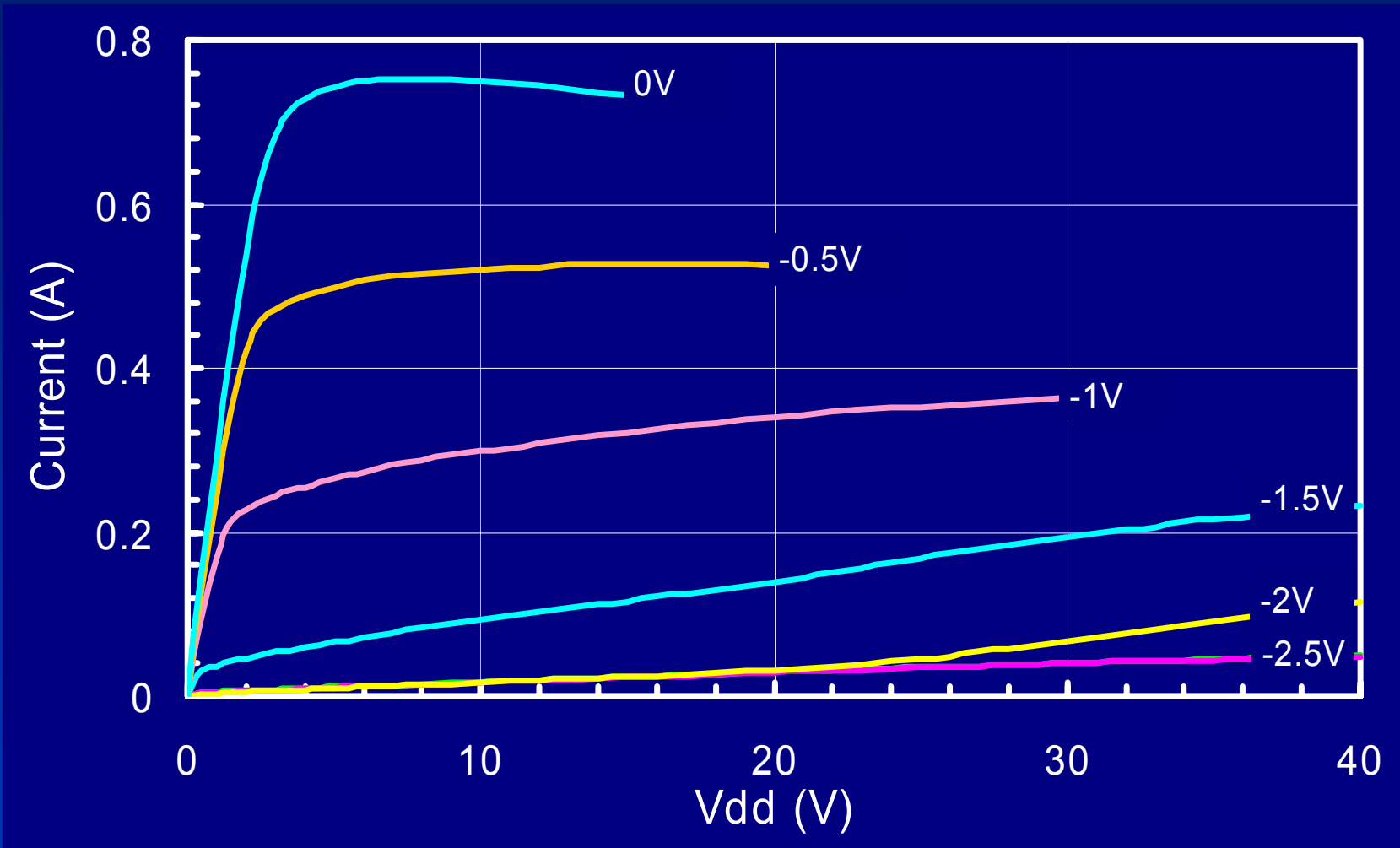

HIFET Device Design

- We have 2 degrees of freedom: N & I_{ds} (Device size)
 - Select a proper cell size
 - Select No. of devices in series
- $R_{opt} = N \cdot (V_{ds} - V_{knee}) / I_{ds}$
- $P_{out} = N \cdot (V_{ds} - V_{knee}) \cdot I_{ds} / 2 = N^2 \cdot (V_{ds} - V_{knee})^2 / 2 R_{opt}$
- Design bias & RF feedback resistors for gain flatness, good input & output VSWR and stability
- Adjust capacitor values for optimum power at frequency of operation
- Air voltage breakdown design rule (~ 0.8 to $3V/\mu m$)

HIFET CMOS Process Details

- 0.18 μm gate length
- Use thick metals for microstrip lines and RF ground.
- Dielectric for RF lines is 2 μm SiO_2
- Silicon Nitride layer for capacitor dielectric
- Implanted n-type resistors (890 Ohms/sq.)
- Thin film resistors
- Basic cell consists of 8 x 10 μm
- HiFET: 2 in-series & 4 in-series: 2 x 80 μm , 4 x 80 μm , 2 x 640 μm , 4 x 640 μm

CMOS Process Outline

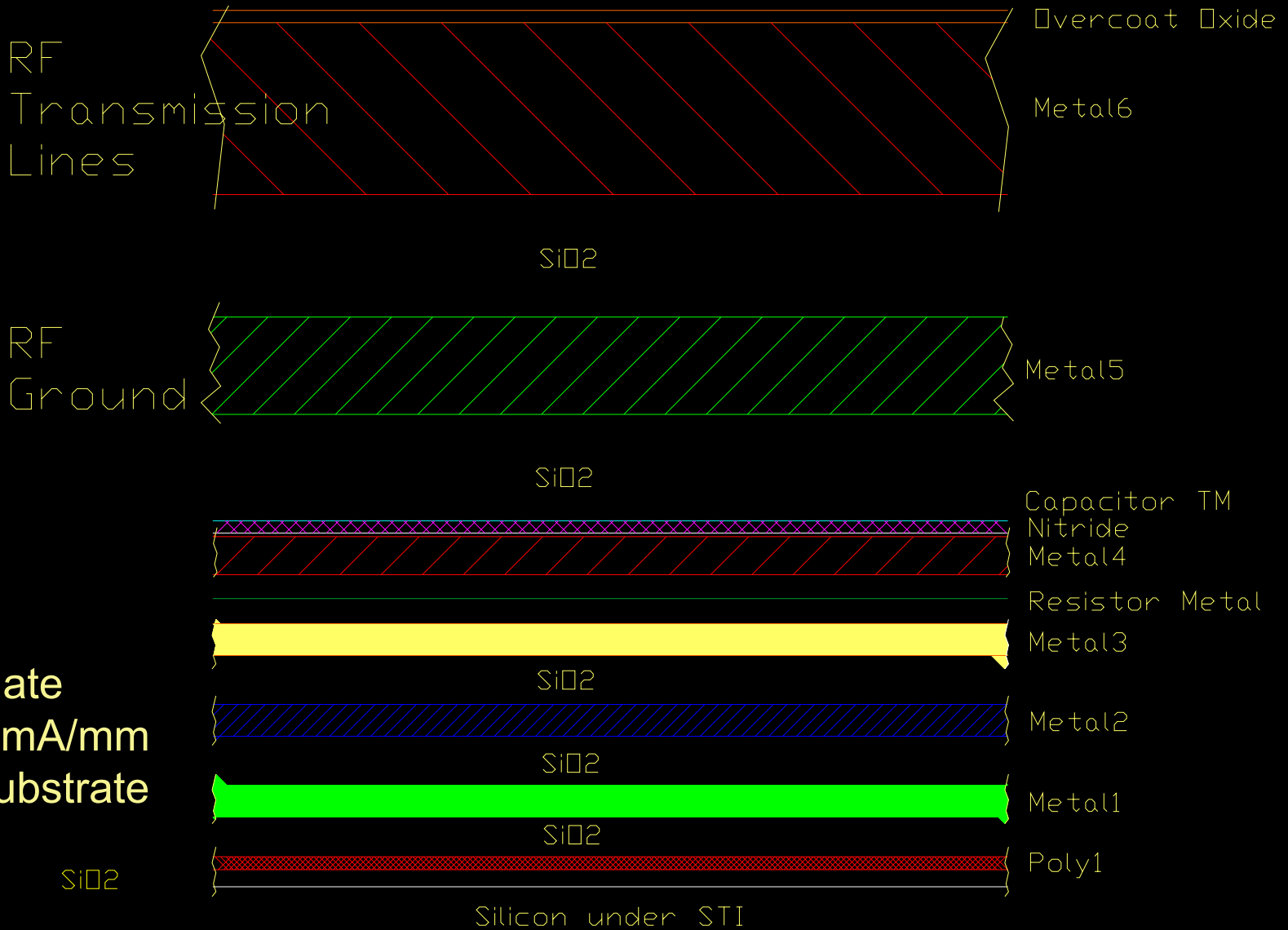

RF
Transmission
Lines

RF
Ground

0.18 μ m gate
Ids ~ 300mA/mm
10 mils substrate

Picture of Fabricated Test Circuits

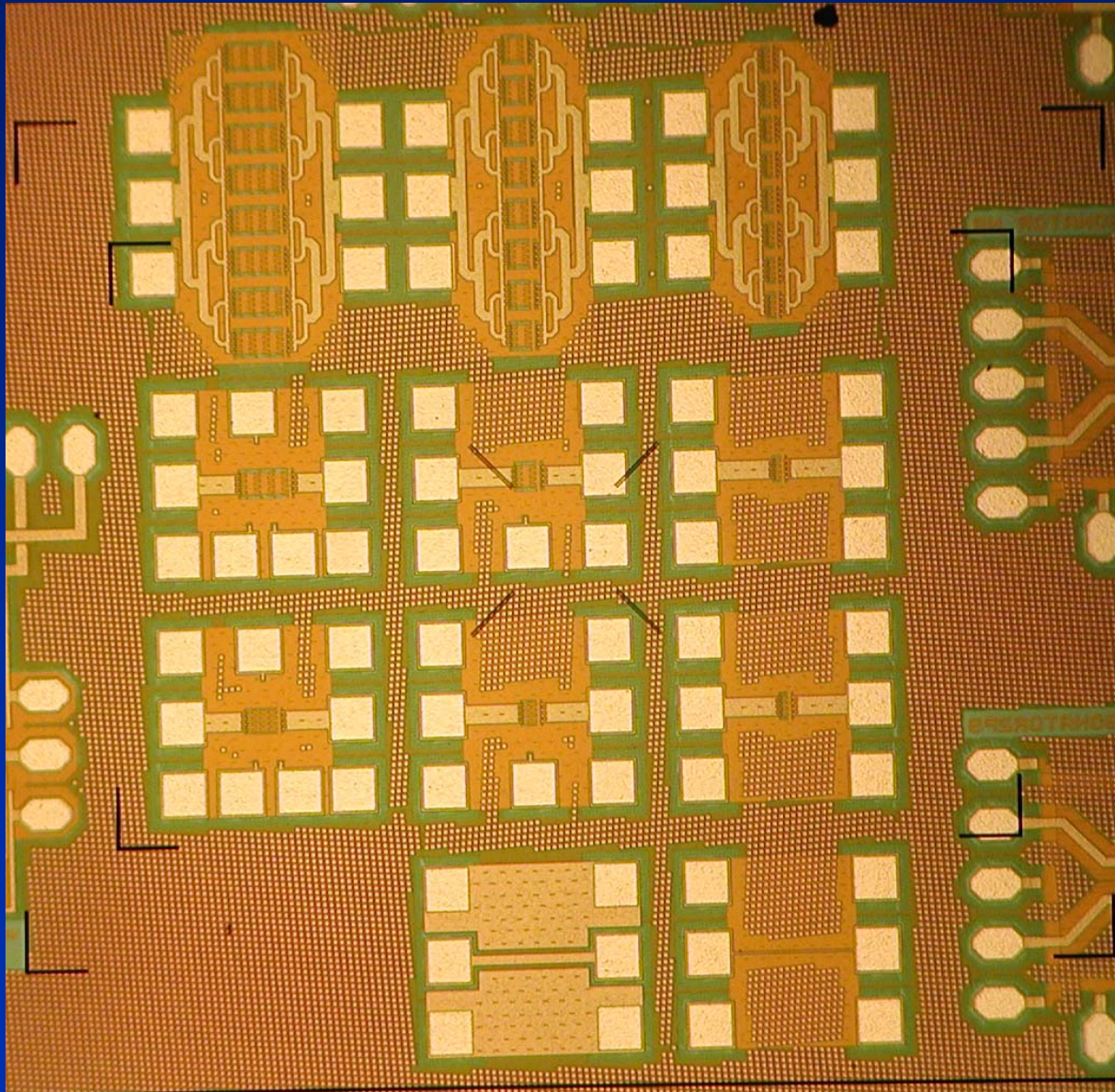

I-V Characteristics of a 80 μm Single Cell, 2 in-series & 4 in-series

80 μm Cell CMOS (No N-Well)

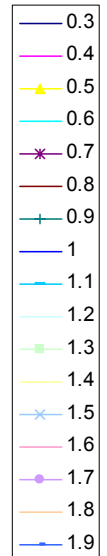
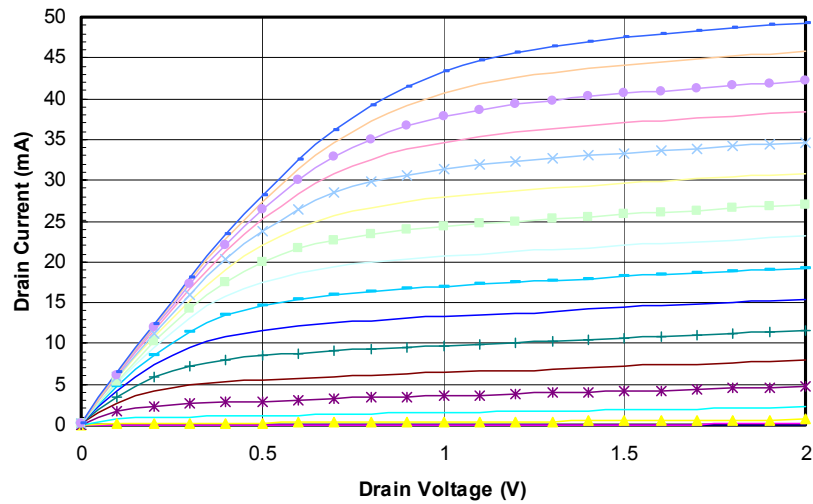

2x80 μm Cell 2 in-series HiFET (S/N 1 with N-Well)

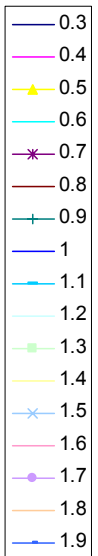
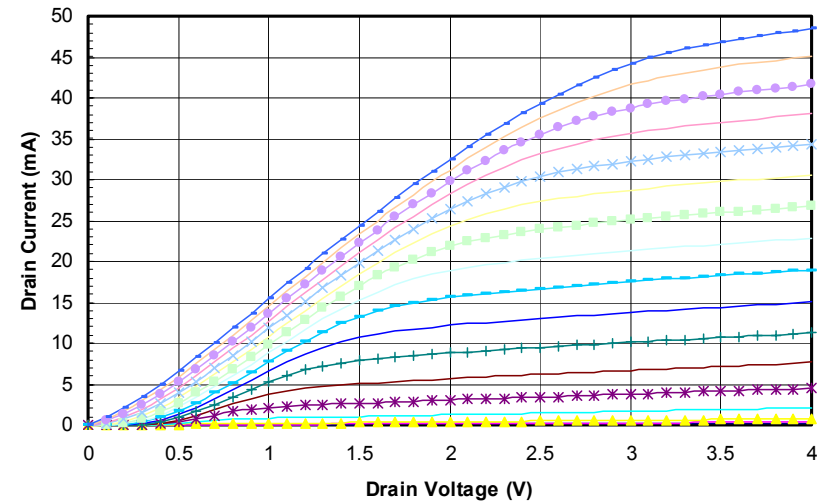

4x80 μm Cell 4 in-series HiFET (S/N 1 with N-Well)

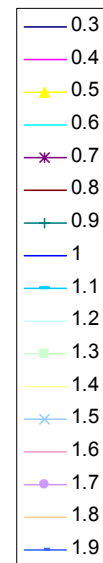
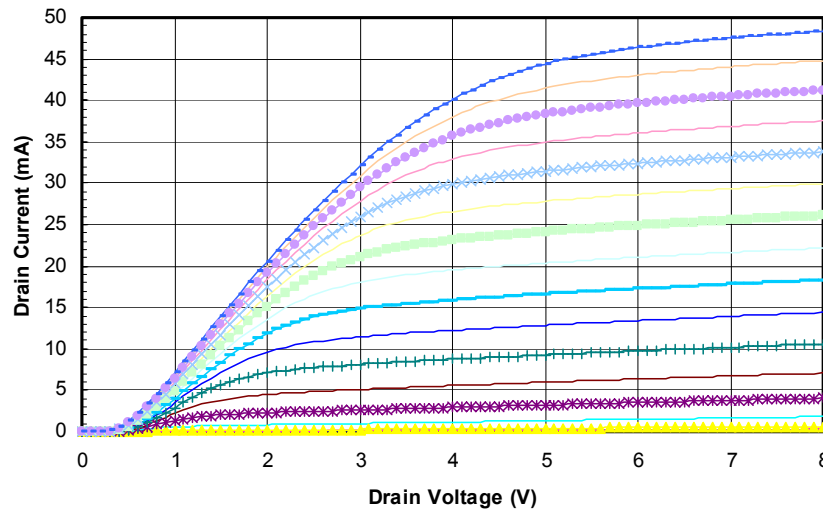

I-V Characteristics of a 640 μm Single Cell, 2 in-series & 4 in-series

640 μm Cell CMOS (S/N 1 with N-Well)

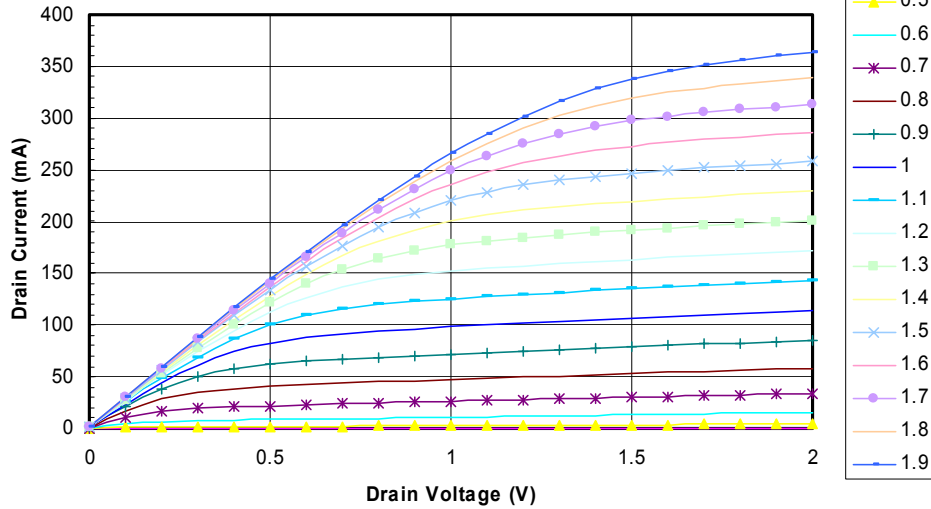

2x80 μm Cell 2 in-series HiFET (S/N 1 with N-Well)

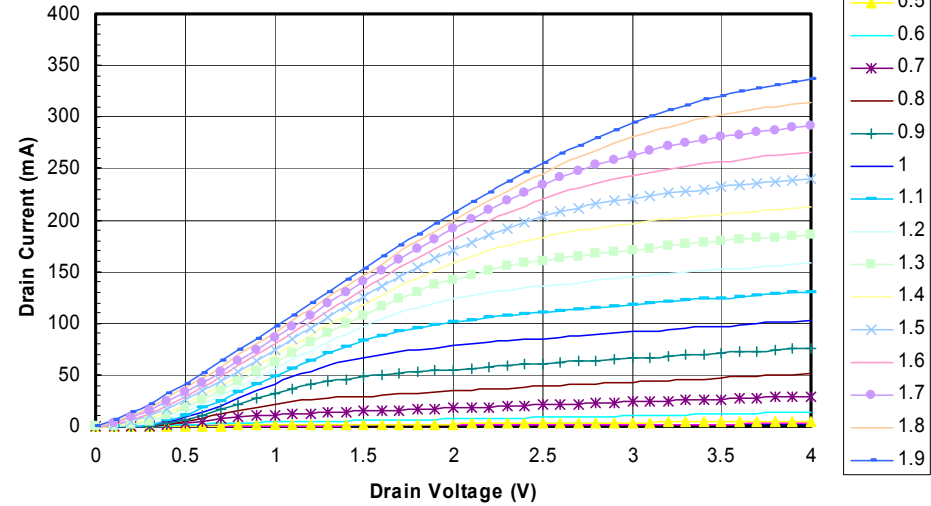

4x 640 μm Cell 4 in-series HiFET (S/N 1 with N-Well)

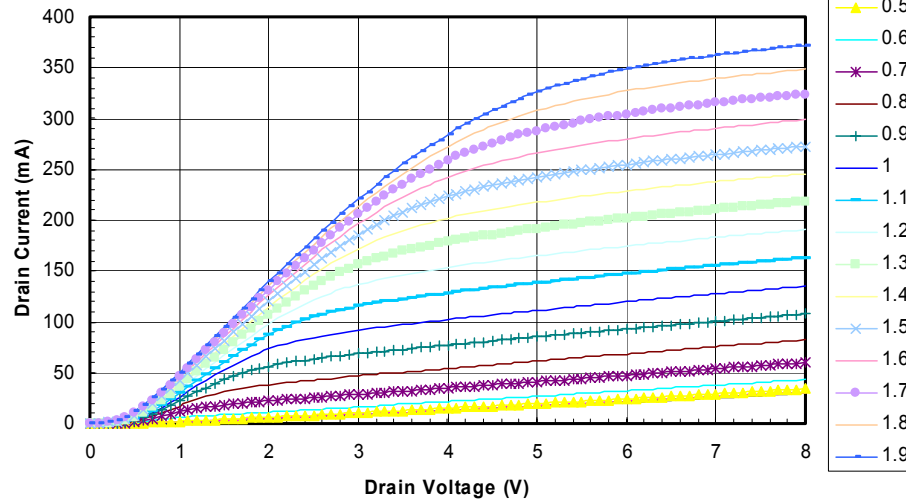

Power of 80 μ m Cell at 1GHz

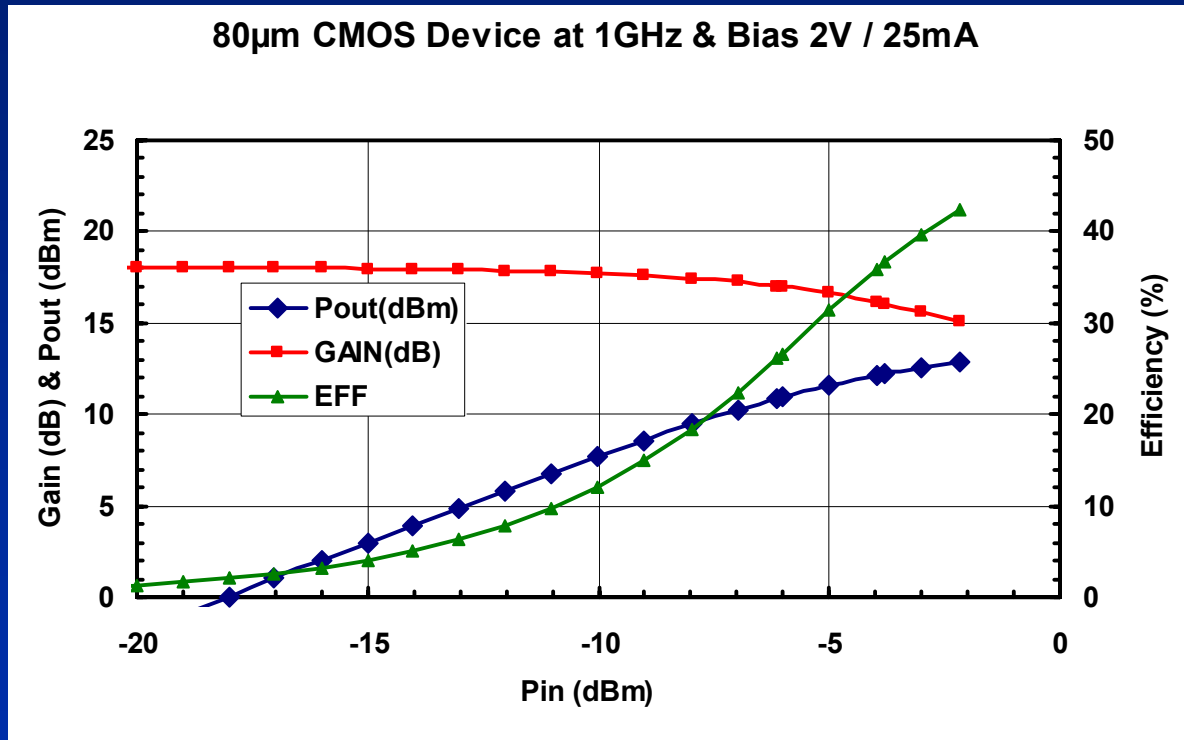
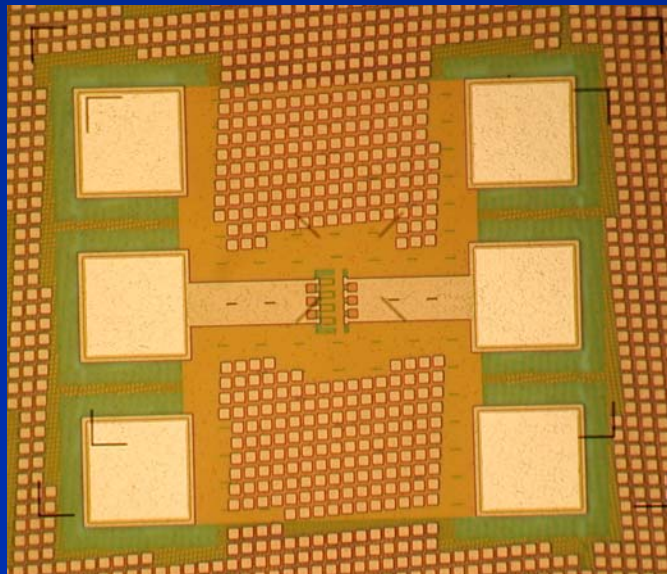
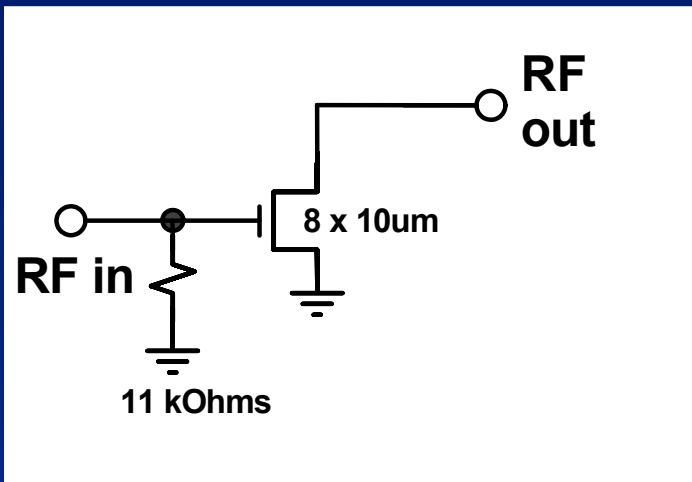

Power of 2 x 80μm HiFET at 1GHz

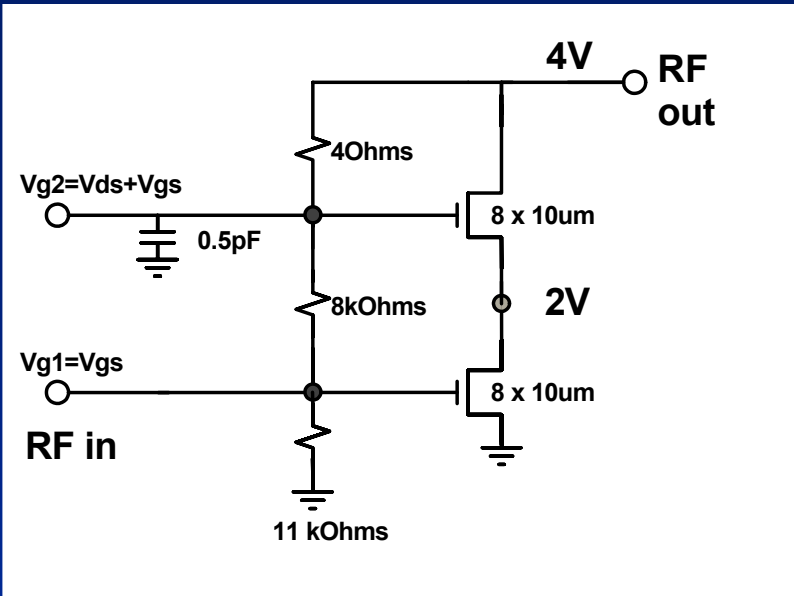

80μm 2 In-Series HiFET at 1GHz & Bias 4V / 25mA

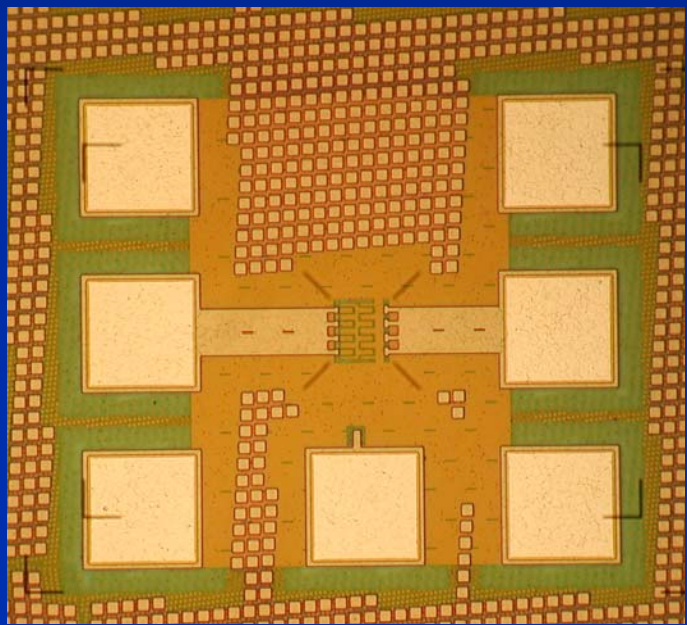
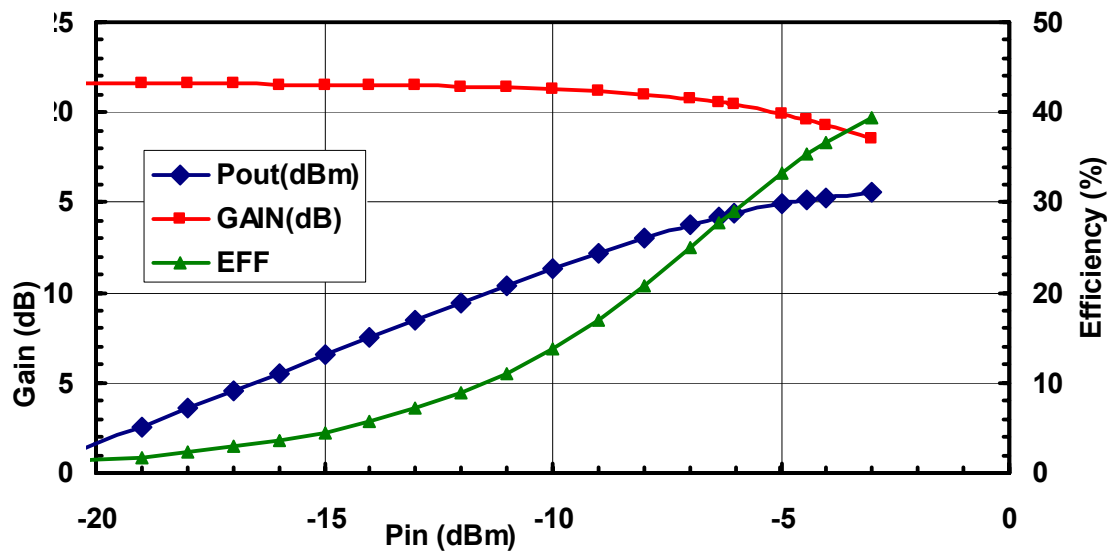

Power of 4 x 80 μ m HiFET at 1GHz

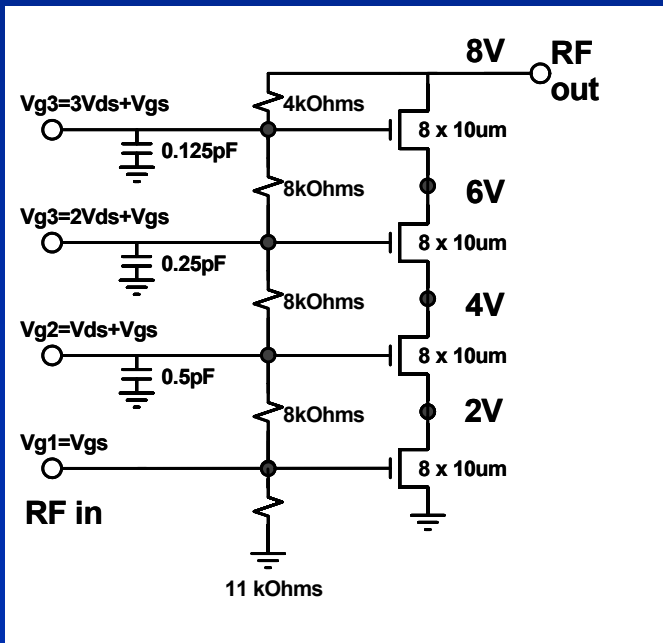
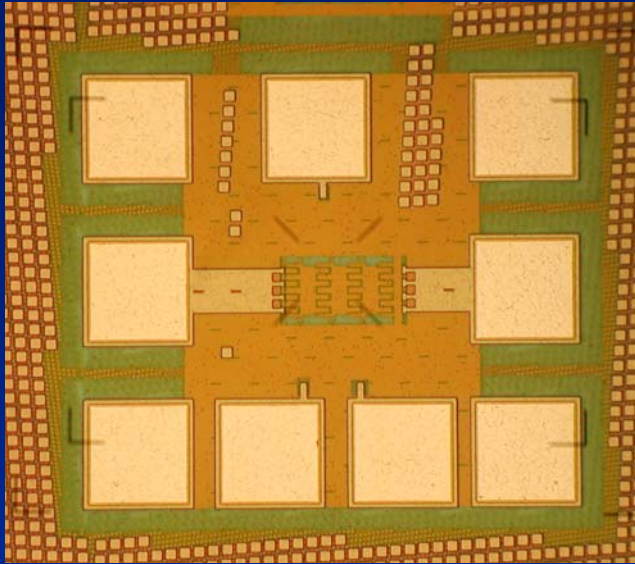

80 μ m 4 In-Series HiFET at 1GHz & Bias 8V / 25mA

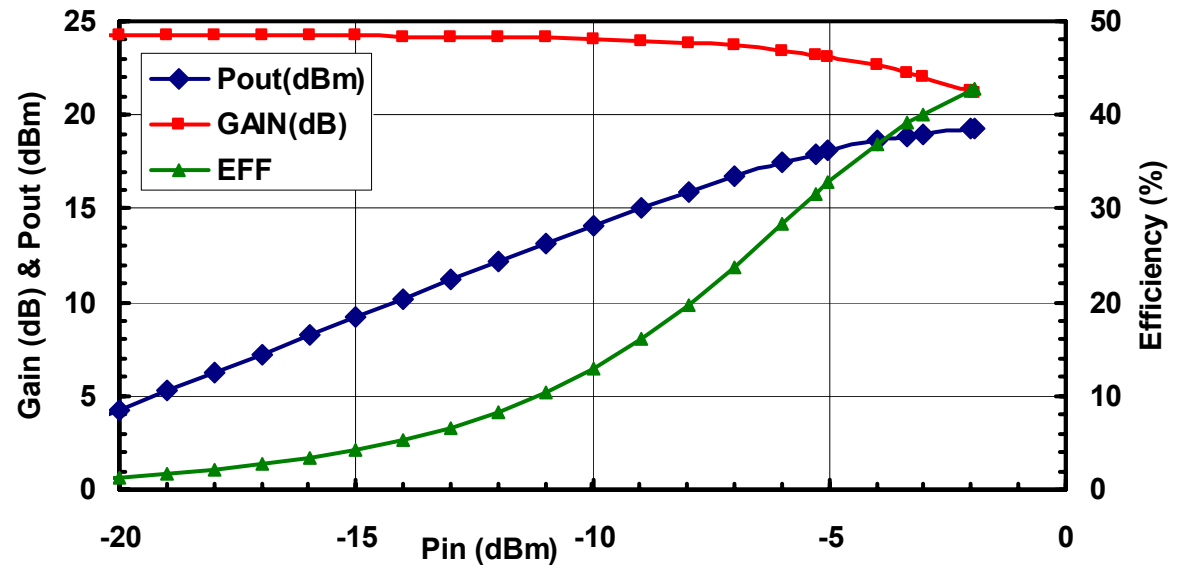

Power of 640 μ m Cell at 1GHz

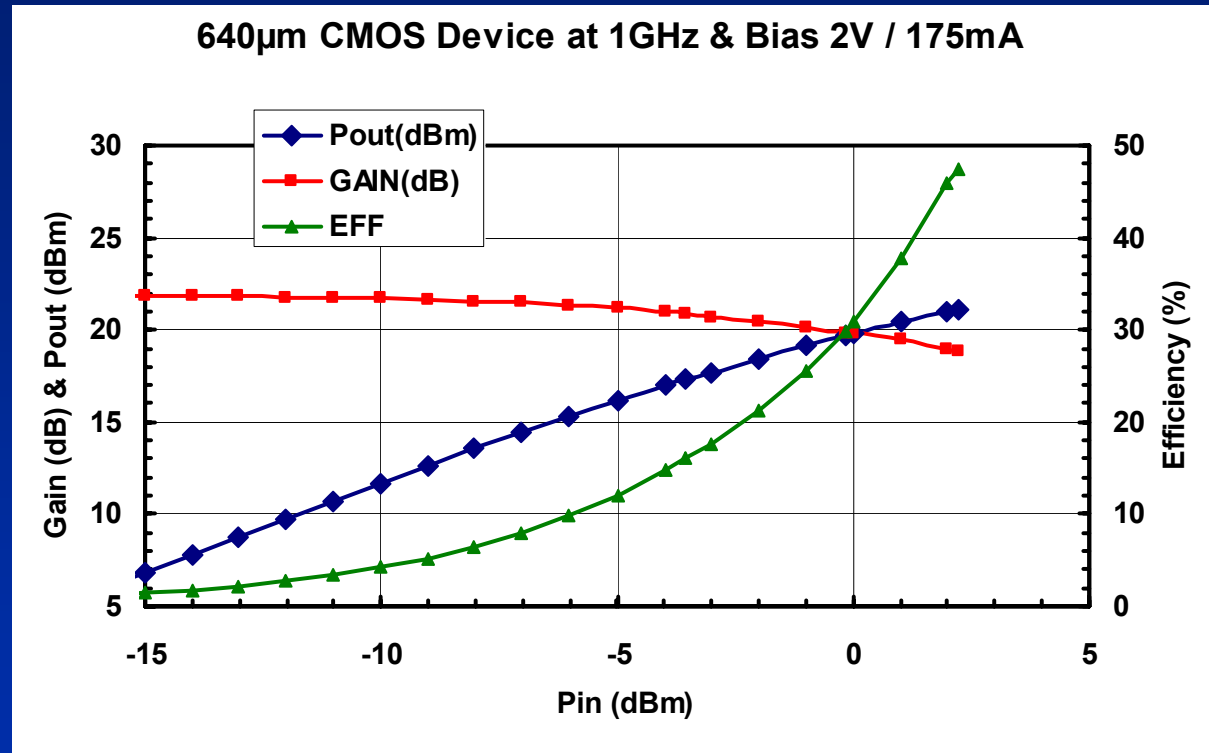
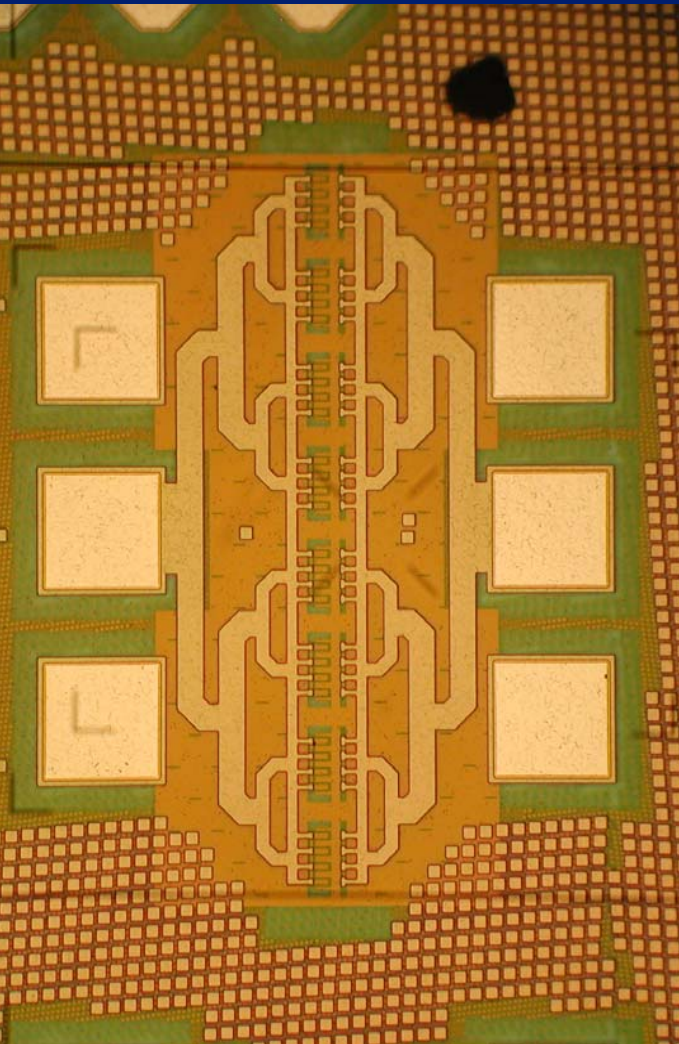

$$R_{\text{opt}} = 10 \Omega$$

Power of 2 x 640 μ m HiFET at 1GHz

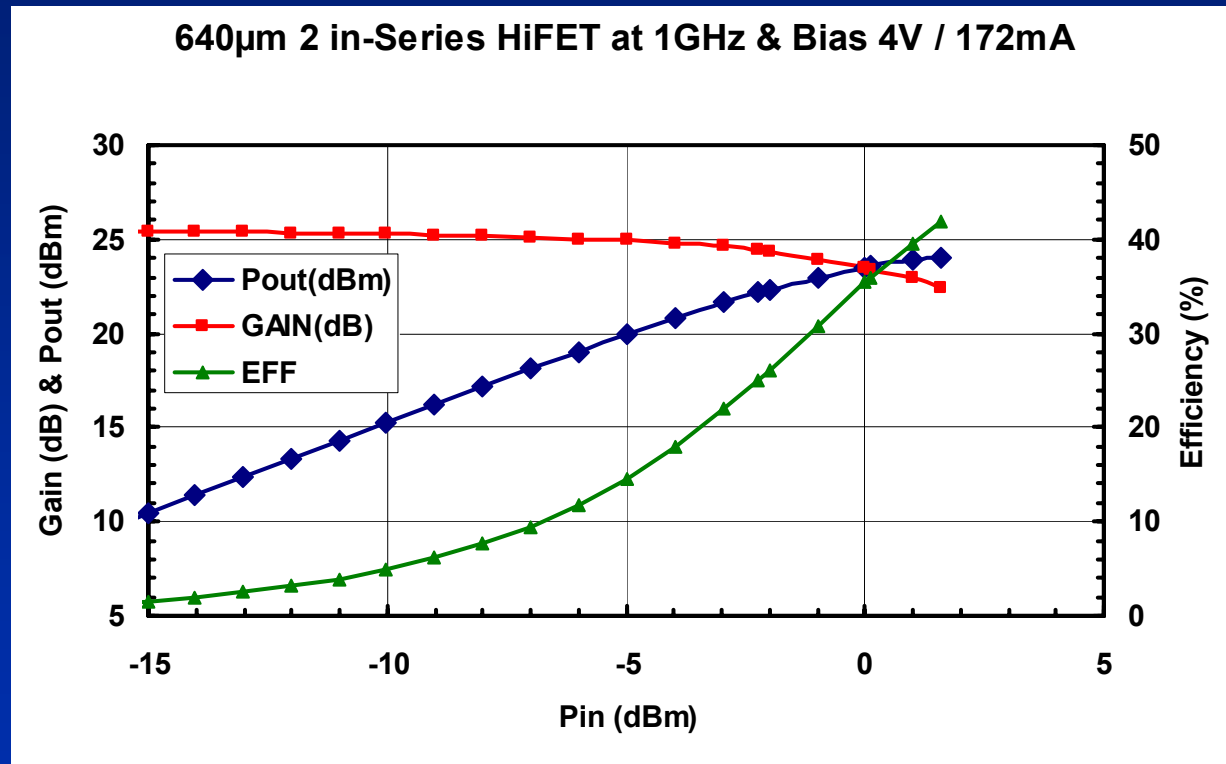
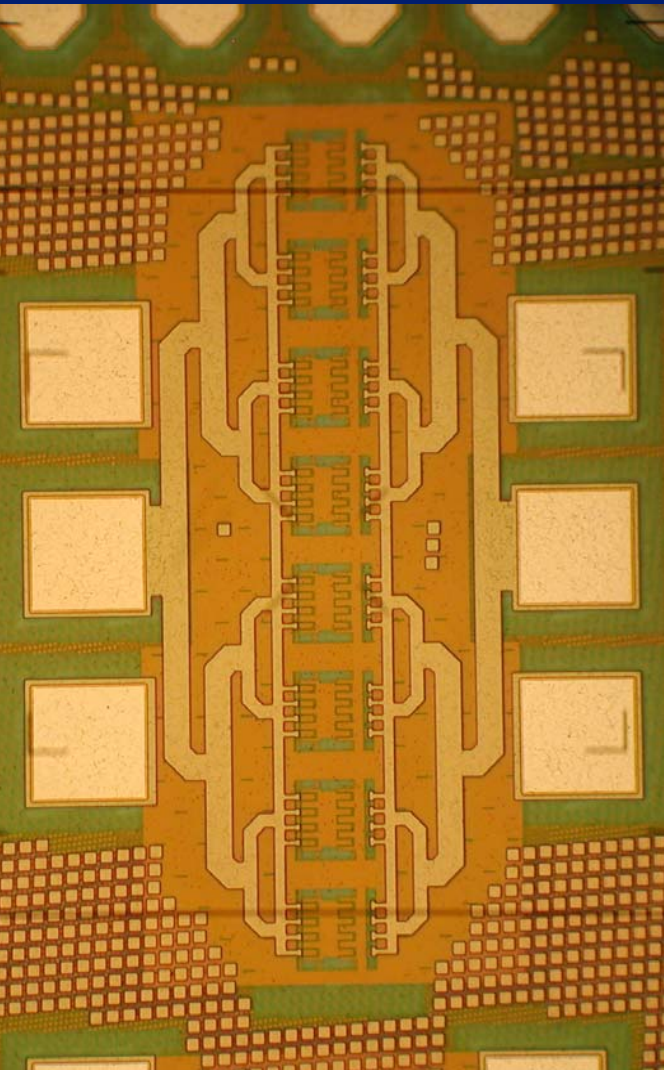

$$R_{opt} = 20 \Omega$$

Power of 4 x 640 μ m HiFET at 1GHz

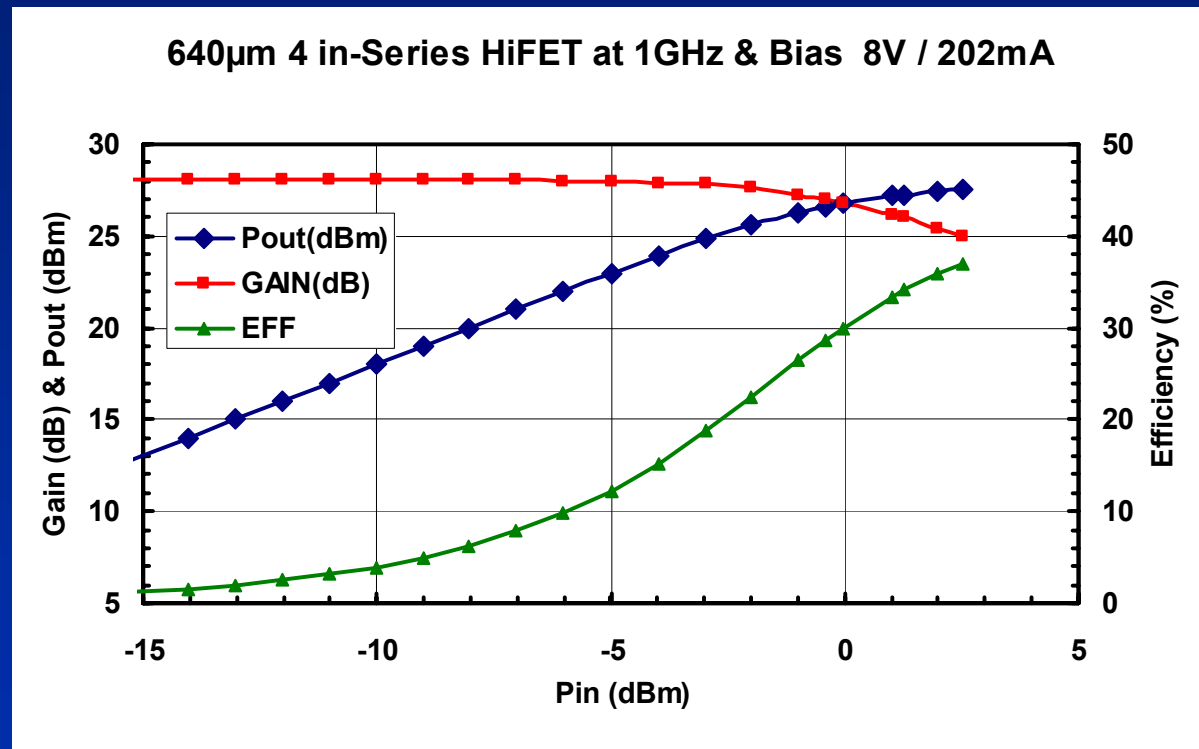
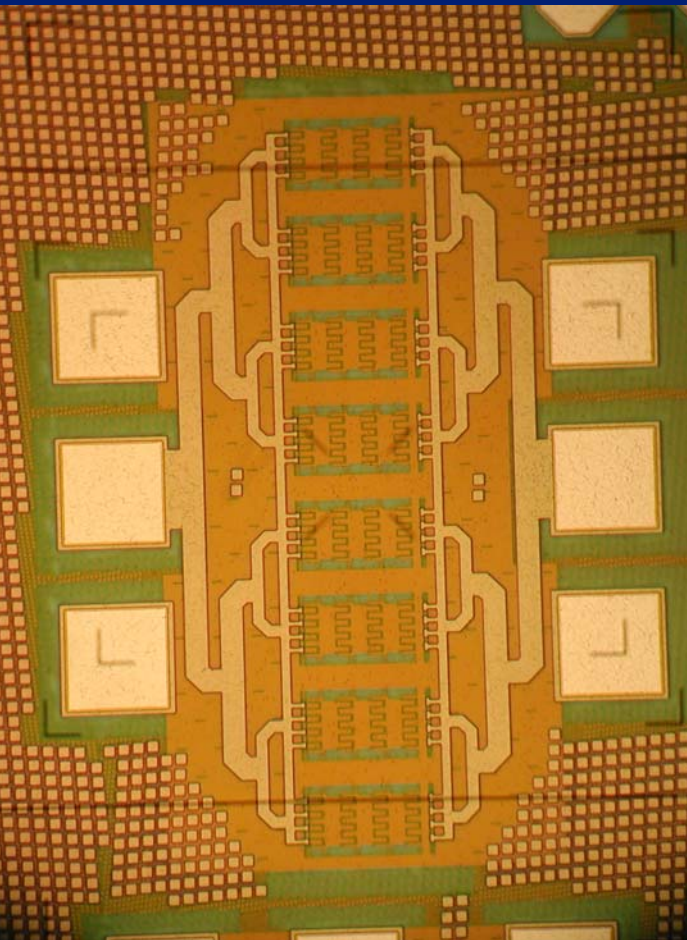

$R_{opt} = 40 \Omega$
(2.5 Ω for 2560 μ m device)

Power and Gain Results at 1GHz

Parameter	80 μm CMOS	2 x 80 μm HiFET	4 x 80 μm HiFET	640 μm CMOS	2 x 640 μm HiFET	4 x 640 μm HiFET
Gain	18.1dB	21.6dB	24.3dB	21.9dB	25.5dB	28dB
$P_{1\text{dB}}$	10.9dBm	14.2dBm	17.9dBm	17.3dBm	22.2dBm	26.6dBm
Efficiency At $P_{1\text{dB}}$	26.1%	27.7%	31.6%	16%	25%	28.7%
P_{sat}	12.9dBm	15.5dBm	19.3dBm	21.1dBm	24.1dBm	27.5dBm
Efficiency At P_{sat}	42.3%	39.4%	42.7%	47.5%	41.8%	36.9%

Conclusion

- HiFET devices using 0.18 μm CMOS process are demonstrated
- The HiFET configuration is applicable to CMOS to overcome low-voltage operation and low power density
- HiFET could help integrating PA on Silicon
- Broadband PA on Silicon is feasible

Acknowledgement

- Jack Singer
- Thomas Shutt
- Dr. Cynthia Hanson & Dr. Dan Radek at DARPA