

DESCRIPTION

AMCOM's AM244236WM-BM-R and AM244236WM-FM-R are part of the GaAs MMIC power amplifier series. Both MMICs have 31dB gain, 36dBm output power over the 2.4 to 4.2 GHz band. These MMICs are in a ceramic package with both RF and DC leads at the bottom level of the package to facilitate low-cost SMT assembly to the PC board. Because of high DC power dissipation, we strongly recommend to mount these devices directly on a metal heat sink. The FM package is the BM package mounted on a copper flange carrier. There are two screw holes on the flange to facilitate screwing on to a metal heat sink. Both MMICs are RoHS compliant.

FEATURES

- Wide bandwidth from 2.4 to 4.2 GHz
- High output power, $P_{1dB} = 36$ dBm
- High gain, 31dB
- Fully matched; 50-ohm input/output impedance

APPLICATIONS

- Wireless Internet Access
- Wireless Local Loop
- Two way radio

PERFORMANCE* ($V_{ds} = 8V$, $I_{dq} = 1500mA$, $V_{gs}^{**} = -0.76V$, $T_a = 25^\circ C$)

Parameters	Minimum	Typical	Maximum
Frequency	2.6 – 4.0 GHz	2.4 – 4.2 GHz	
Gain (Small signal)	27 dB	31 dB	
Gain Ripple		± 2.0 dB	± 3 dB
P_{1dB}	35.0 dBm	36.0 dBm	
P_{sat}		36.5 dBm	
Efficiency	20 %	30 %	
Input Return Loss	8 dB	15 dB	
Output Return Loss	8 dB	12 dB	
Thermal Resistance		6.1 $^\circ C/W$	

* Specifications subject to change without notice

** Gate voltage is for reference only and may vary from lot to lot

ABSOLUTE MAXIMUM RATING

Parameter	Symbol	Rating
Drain source voltage	V_{ds}	10 V
Gate source voltage	V_{gs}	-5 V
Drain source current	I_{ds}	2.4 A
Continuous dissipation at room temperature	P_t	24 W
Channel temperature	T_{ch}	175 $^\circ C$
Operating temperature	T_{op}	-55 $^\circ C$ to +100 $^\circ C$
Storage temperature	T_{sto}	-55 $^\circ C$ to +135 $^\circ C$

SMALL SIGNAL DATA

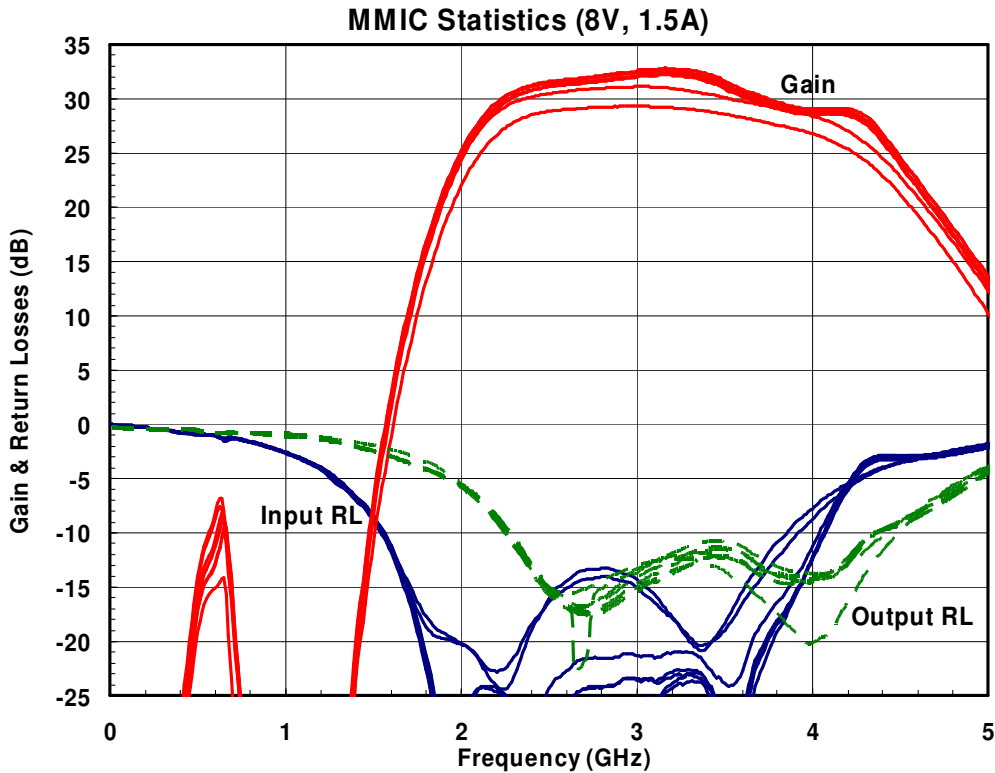

POWER DATA

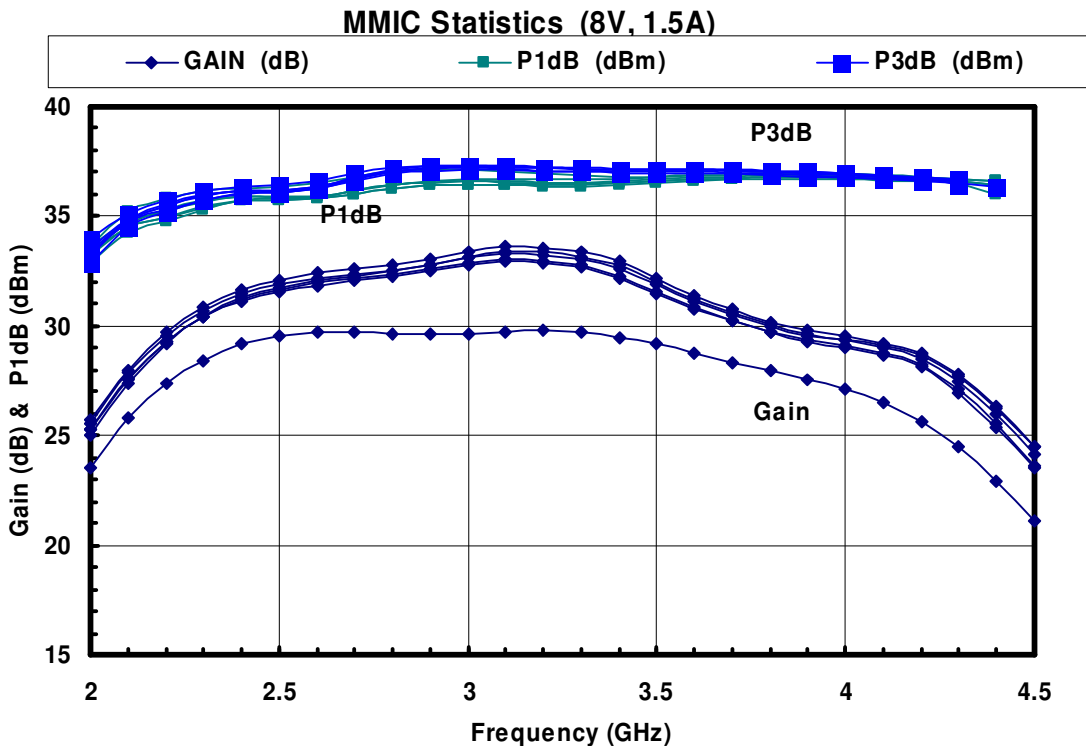

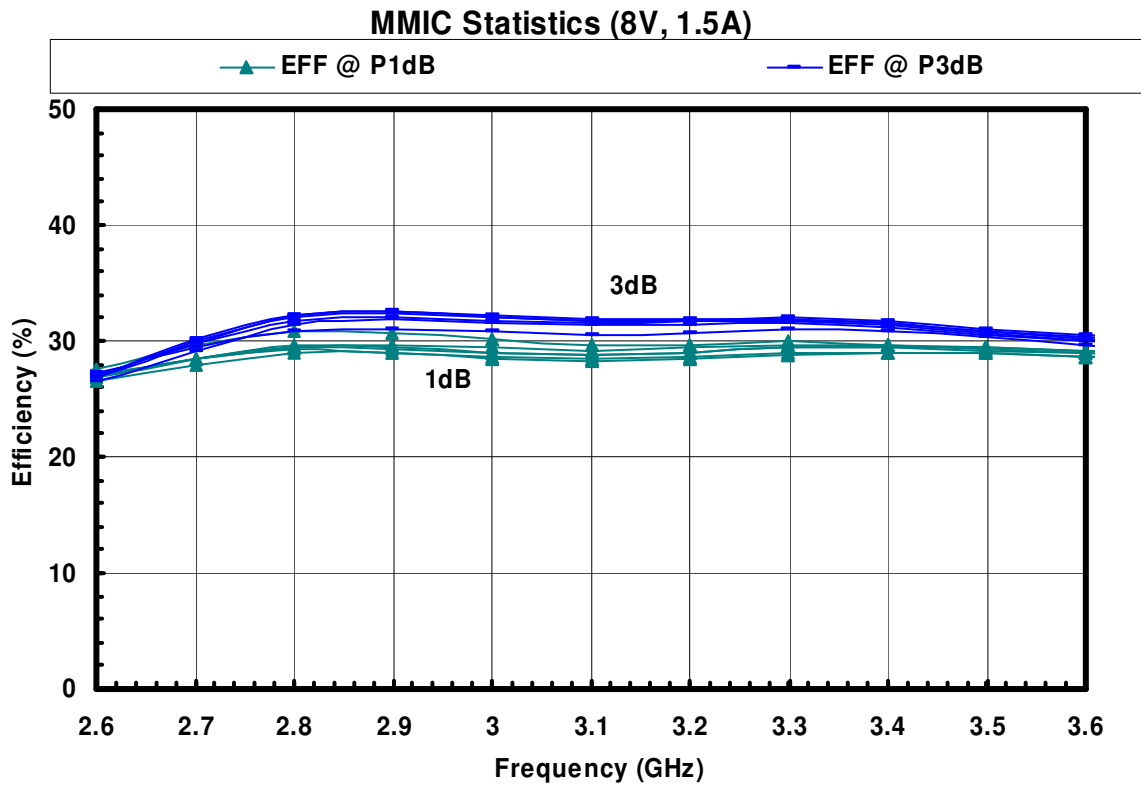

PACKAGE OUTLINE (BM)

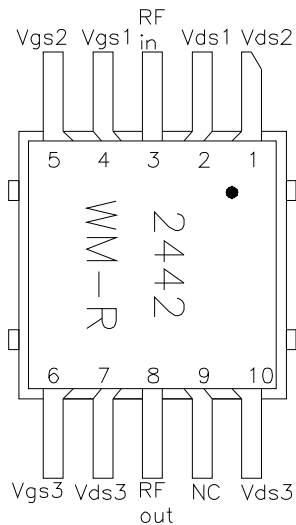
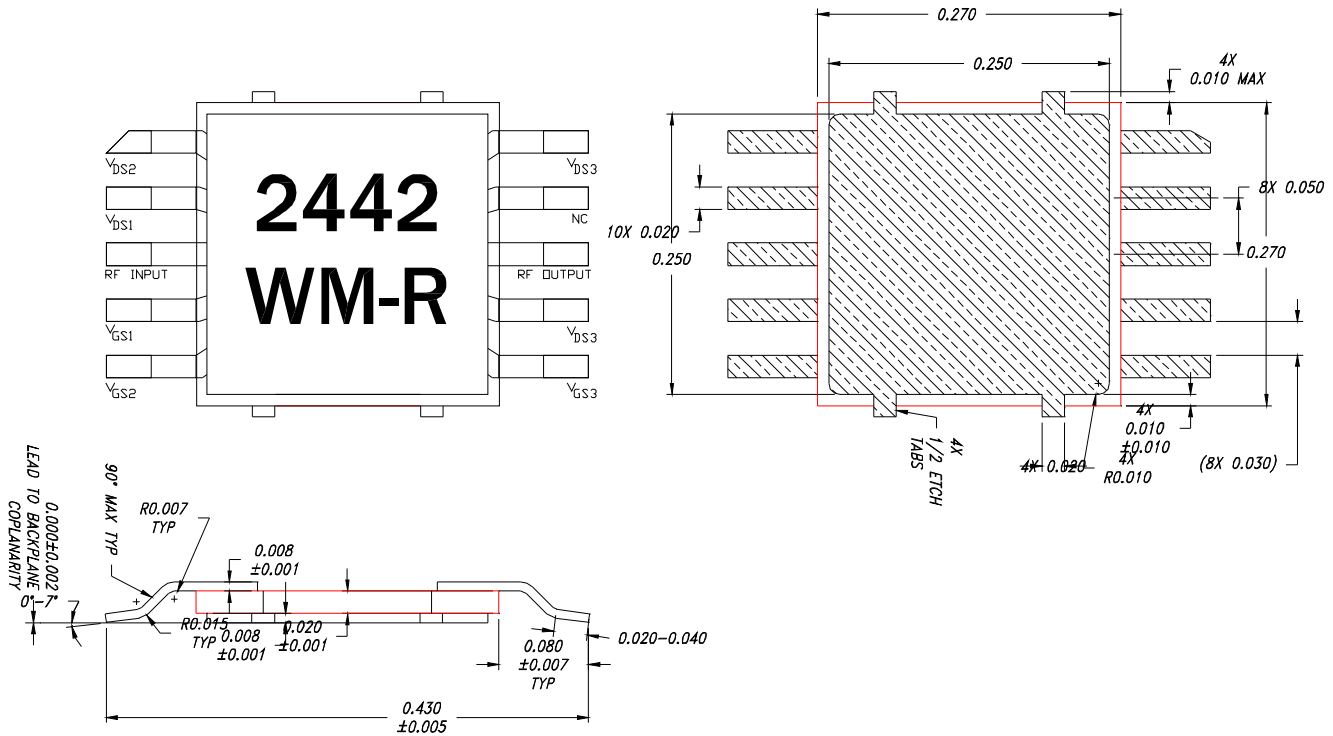

Pin No.	Function	Bias*
1	Vds2	+8V
2	Vds1	+8V
3	RF in	
4	Vgs1	-0.75V
5	Vgs2	-0.75V
6	Vgs3	-0.75V
7	Vds3	+8V
8	RF out	
9	NC	
10	Vds3	+8V

* Gate voltage is for reference only and may vary from lot to lot

PACKAGE OUTLINE (FM)

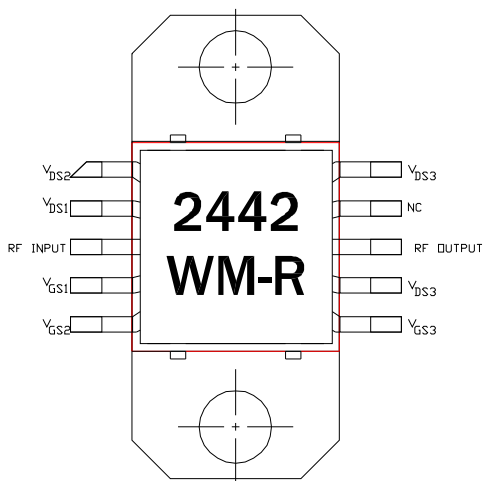
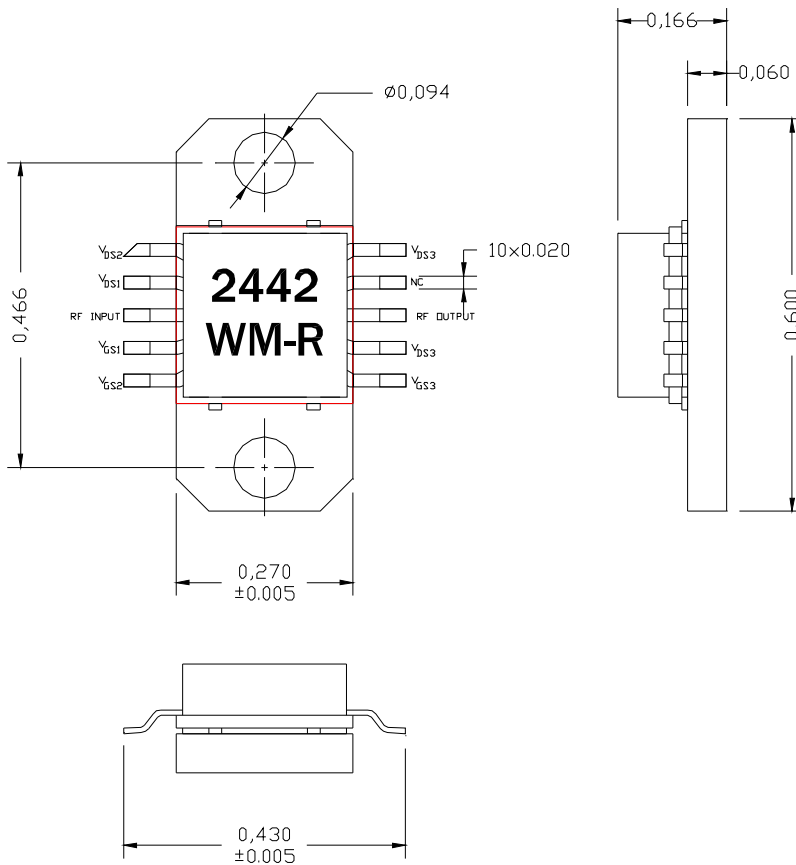

Pin No.	Function	Bias*
1	V _{ds2}	+8V
2	V _{ds1}	+8V
3	RF in	
4	V _{gs1}	-0.75V
5	V _{gs2}	-0.75V
6	V _{gs3}	-0.75V
7	V _{ds3}	+8V
8	RF out	
9	NC	
10	V _{ds3}	+8V

Pin Layout

* Gate voltage is for reference only and may vary from lot to lot

TEST CIRCUIT OUTLINE (BM Package)

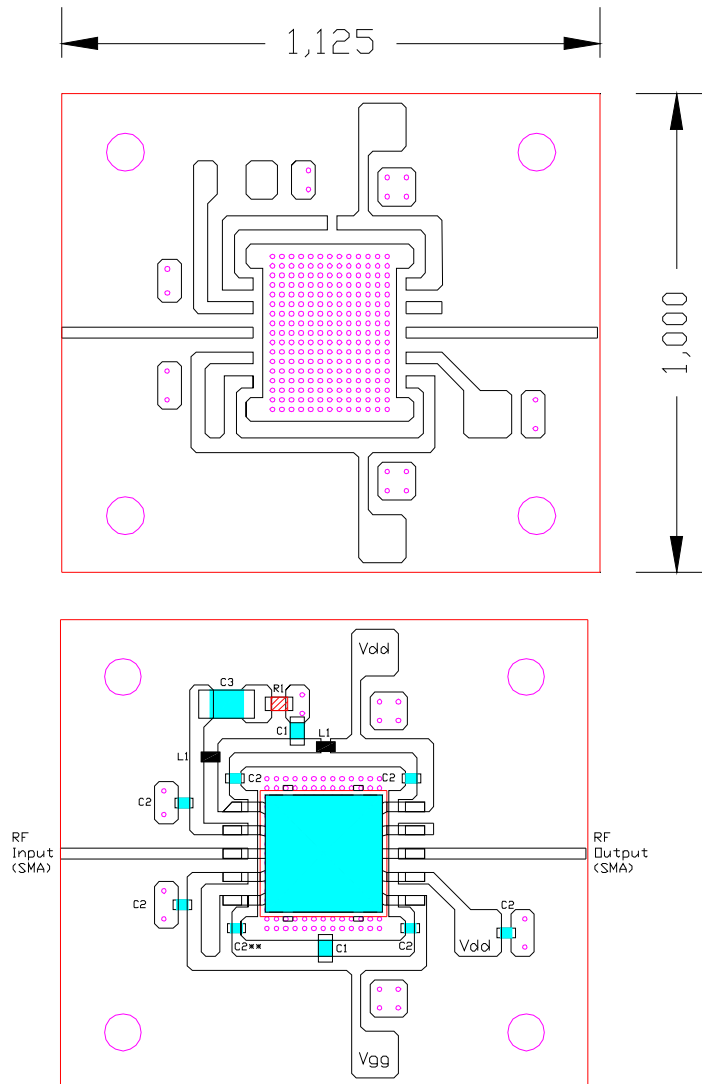

Notes:
 1- 10mils Rogers 4350 Material epoxied to D0007-0021A
 2- Ckt is for matched MMICs
 3- C1=0.56uF (0603), C2=1000pF (0402), C3=10uF (1206), R1=3 ohms (0603), L1=1nH (0402), ** May be omitted

Important Notes:

- 1- The MMIC should have a good heat sink to avoid overheating. If SMT is used use PC board thickness < 10mils and ensure vias are filled with solder or metal to lower PCB heat resistance. MMIC could be attached on direct ground for lowest junction temperature.
- 2- Recommended current biases are 125mA, 275mA & 1100mA for the first,second and third stages respectively.
- 3- Do not apply V_{ds1} , V_{ds2} & V_{ds3} without proper negative voltages on V_{gs1} , V_{gs2} & V_{gs3} .
- 4- The currents flowing out of the V_{gs1} , V_{gs2} & V_{gs3} pins are less than 100 μ A, 500 μ A & 10mA at P_{1dB} .