

DESCRIPTION

AMCOM's AM006041SD-2H is an ultra-broadband GaN MMIC power amplifier. It has 21dB gain, and >42dBm output power over the 0.03 to 6GHz band. The AM006041SD-2H is a drop-in carrier to be screwed to a metal heat sink. This part is RoHS compliant.

FEATURES

- Ultra wide bandwidth from 30MHz to 6GHz
- Saturated output power Psat > 42dBm
- High small signal gain, 21dB
- Input matched to 50 Ohms

APPLICATIONS

- Software Radio, ECM
- Instrumentation
- Gain block

TYPICAL PERFORMANCE *

(Bias Conditions**: $V_{ds1} = +25V$, $I_{dq1} = 400mA$, $V_{dd2} = +60V$, $I_{dq2} = 1000mA$, 100 μ s pulse, 10% duty cycle)

Parameters	Minimum	Typical **	Maximum
Frequency	0.1 – 5GHz	0.03 – 6GHz	
Small Signal Gain	17dB	21dB	25dB
Gain Ripple		$\pm 2dB$	$\pm 3.0dB$
P1dB @ 0.5GHz	40dBm	42dBm	
P1dB @ 3.0GHz	39dBm	41dBm	
P1dB @ 6.0GHz		39dBm	
Psat @ 0.5GHz	43dBm	45dBm	
Psat @ 3.0GHz	41dBm	43dBm	
Psat @ 6.0GHz	40dBm	42dBm	
Psat Efficiency @ 0.5GHz		47%	
Psat Efficiency @ 3.0GHz		36%	
Psat Efficiency @ 6.0GHz		23%	
Noise Figure		TBD	
IP3		TBD	
Input Return Loss	15dB	17dB	
Output Return Loss		5dB	
Thermal Resistance		TBD	

* Specifications subject to change without notice.

** Data obtained using test fixture shown in this datasheet. Gate biases corresponding to above currents are $V_{gs1} = -3.75V$, $V_{gs2} = -3.75V$, and may vary from lot to lot.

ABSOLUTE MAXIMUM RATING (10% Pulse)

Parameters	Symbol	Rating
First stage drain voltage	V_{ds1}	35V
Second stage drain source voltage	V_{dd2}	70V
Gate source voltage	V_{gs1} & V_{gs2}	-6V
Drain source current	I_{dq1}	0.7A
Drain source current	I_{dq2}	1.75A
Continuous dissipation at 25°C	P_t	40W
Channel temperature	T_{ch}	175°C
Operating temperature	T_{op}	-55°C to +85°C
Storage temperature	T_{sto}	-55°C to +135°C

SMALL SIGNAL DATA

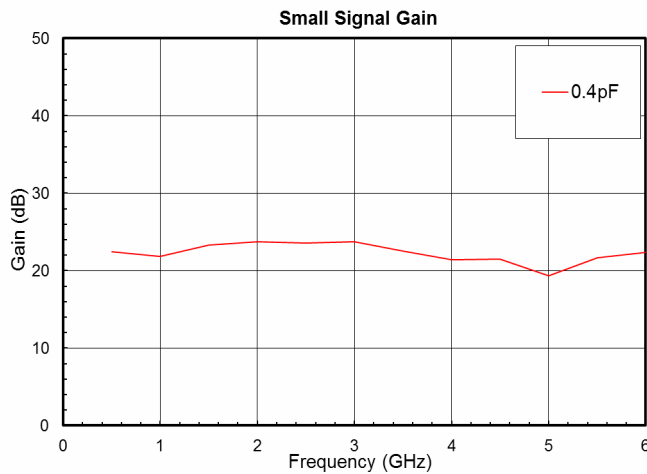

a) Gain under 10%pulse duty cycle

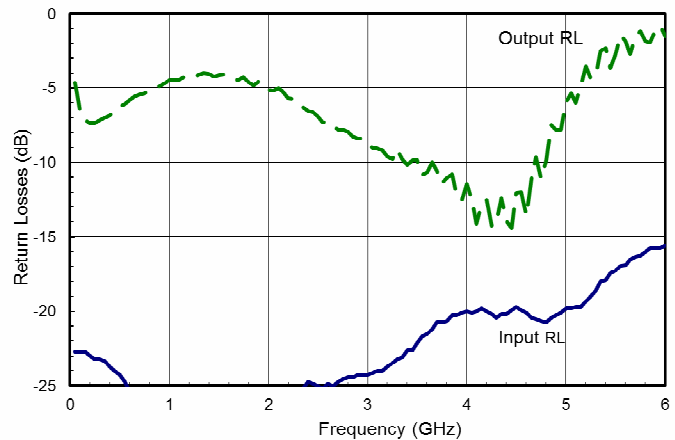

b) Input & output return losses under CW conditions

* S-Parameters measured under CW using bias tee and a matching circuit for 0.03 to 5GHz band. Bias is $V_{dd1}=25V$, $V_{ds2}=30V$, $I_{dq1}=200mA$, $I_{dq2}=300mA$, $V_{gs1}=-3.75V$, $V_{g2}=-3.75V$.

NOISE DATA

(TBD)

PULSED POWER DATA*

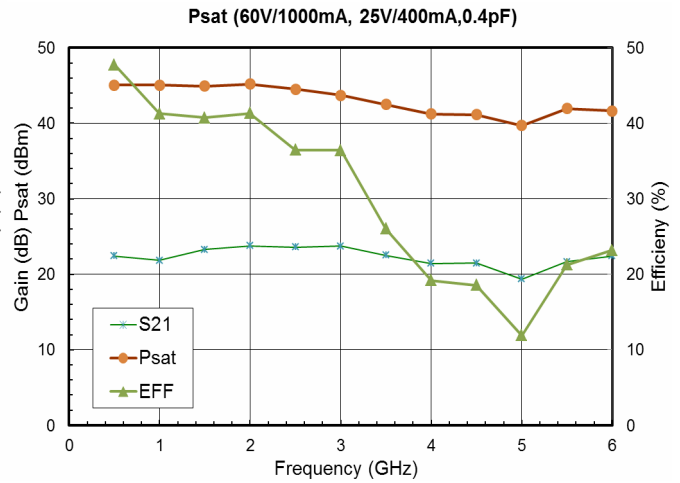
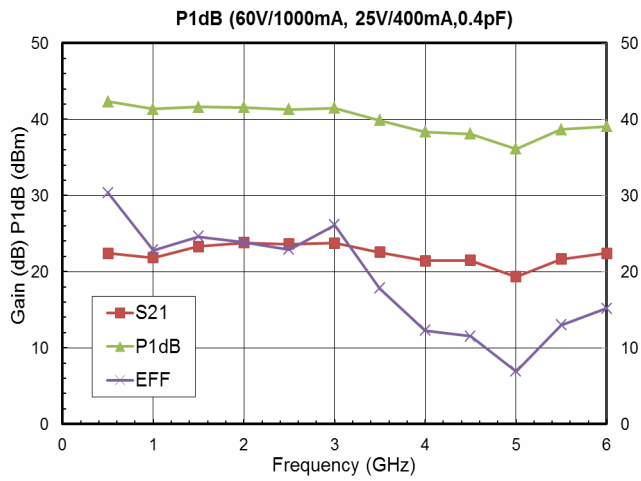

* Power measured under pulse conditions. Pulse is 100µsec with 10% duty cycle. Bias is $V_{ds1}=25V$, $V_{dd2}=60V$, $I_{dq1}=400mA$, $I_{dq2}=1000mA$

CARRIER OUTLINE (AM006041SD-2H)

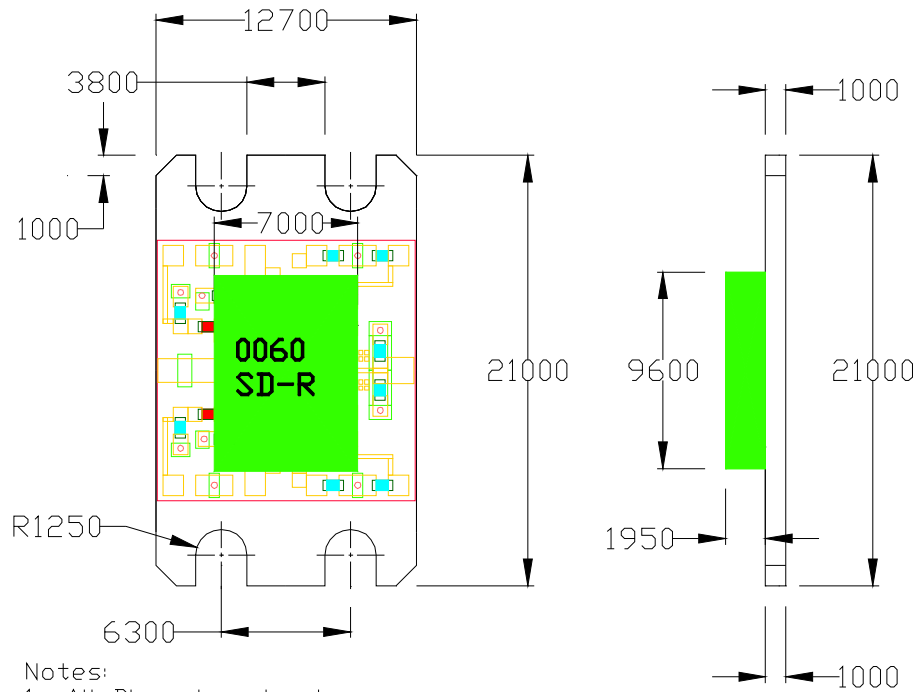

- Notes:
- 1- All Dimensions in microns
 - 2- Material: Copper Tungsten
 - 3- Tolerance < 0.003
 - 4- Finish: Plate Au 3um min per ASTM-B-488-95 Type III Class B

- Gate biases are for reference only and may vary from lot to lot.

Pin Layout

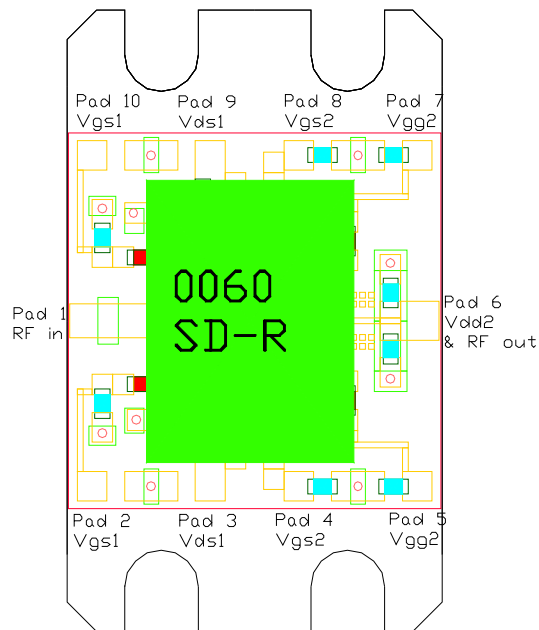

Pin No.	Function	Bias
1	RF in	
2	Vgs1	-3.75V
3	Vds1	+25V
4	Vgs2	-3.75V
5	Vgg2	+60V
6	Vdd2 & RF out	+60V
7	Vgg2	+60V
8	Vgs2	-3.75V
9	Vds1	+25V
10	Vgs2	-3.75V

TEST CIRCUIT for 0.03 – 6GHz

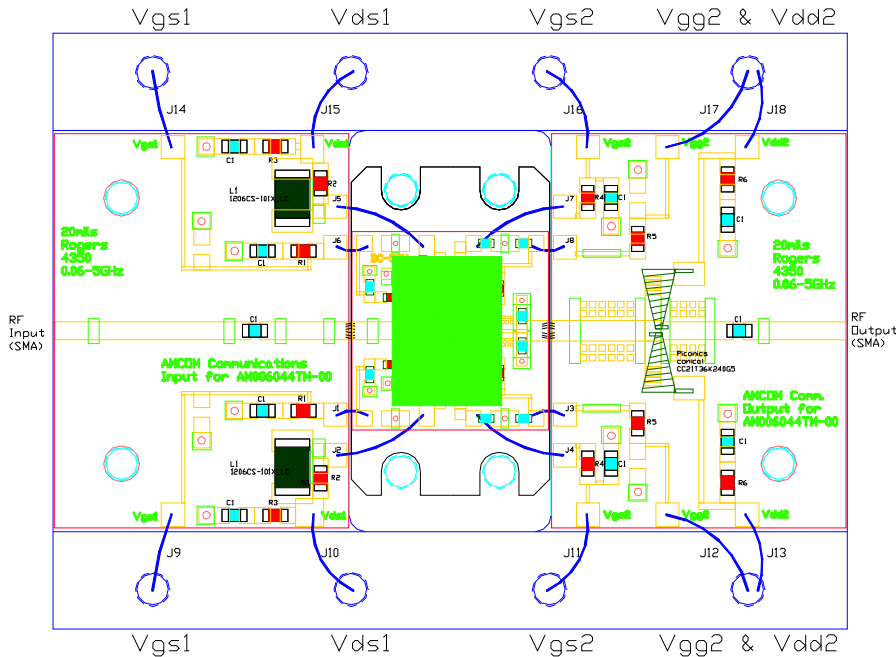

- Notes:
- 1- 20mils Rogers 4350 Material epoxied
 - 2- Ckt is for AM006044TM-00 MMIC
 - 3- C1=1000pF,
R1=100 Ohms, R2=170 Ohms, R3=18 Ohms ,
R4=75 & R5=200 Ohms , R6=25 Ohms
 - 4- All Caps & Resistors are 0603 size
 - 5- Inductors are coilcraft 1206CS-101X_LC
& L2= 11nH (0603CS-11NXJLU)

Important Notes:

- 1- The +60V Bias to the output port could be provided via a bias tee or suitable chokes to be soldered on the board. Inductance of choke should be large enough to have high impedance at lowest frequency of operation (300nH is adequate).
- 2- Recommended pulsed current biases are 400mA and 1000mA for the first stage and second stage respectively. Gate biases of -3.75V are for reference only. V_{gs1} & V_{gs2} could be adjusted to vary the currents going thru the first stage (V_{ds1} pin) and the second stage (V_{dd2} pin) respectively.
- 3- Do not apply V_{ds1} & V_{dd2} without proper negative voltages on V_{gs1} & V_{gs2} .