

DESCRIPTION

AMCOM's AM030WX-BH-R is part of the BH series of GaAs pHEMTs. This part has a total gate width of 3mm. The AM030WX-BH-R is designed for high power microwave applications, operating up to 10 GHz. The BH series is in a ceramic package with leads bent in a surface mounting style on PC Board. The bottom of the package serves simultaneously as DC ground, RF ground, and thermal path. For frequencies above 5 GHz, we recommend to mount the device directly on a metal heat sink, which is also RF ground, to avoid the inductance of via holes on PCB. This part is RoHS Compliant.

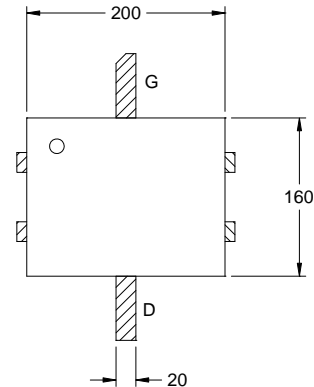

FEATURES

- High Frequency Operation up to 10 GHz
- High Gain & High Power, $P_{1dB}=34dBm$ @4GHz
- Surface Mountable
- Bottom ground for Effective Heat Removal

APPLICATIONS

- Wireless Local Loop Network
- Cellular Radio Communications
- WLAN, Repeaters & HYPERLAN
- C-Band VSAT
- Radar

RF PERFORMANCE @ 4 GHz, ($V_{ds} = 8V$, $I_{ds} = 0.3A$)

Parameters	MIN	TYP
P_{1dB} * (dBm)	32	34
Eff @ P_{1dB}	40%	49%
Small Signal Gain (dB)	9	10.8
IP3 (dBm)	40	42

* Power typically remains the same as frequency changes.

ABSOLUTE MAXIMUM RATING

Parameters	Sym	Rating
Drain-Source Voltage (V)	V_{ds}	10
Gate-Source Voltage (V)	V_{gs}	-5
Drain Current (A)	I_{ds}	0.9
Continuous Dissipation At Room Temp. (W)	P_t	5.7
Operating Temp. ($^{\circ}C$)	T_A	-55 to +85
Max. Channel Temp. ($^{\circ}C$)	T_{ch}	+175

DC PARAMETERS

Parameters	Conditions	MIN	TYP	MAX
Saturation Current I_{dss} (A)	$V_{ds}=3V$, $V_{gs}=0V$	0.6	0.9	1.2
Pinch-off Voltage V_p (V)	$V_{ds}=3V$, $I_{ds}=2.5\% I_{dss}$	-2.2	-1.7	-1.2
Drain to Gate Breakdown Voltage BV_{gd} (V)	$I_{dg} = 1mA/mm$	15	20	
Thermal Resistance ($^{\circ}C/W$)			26	

SMALL SIGNAL MEASUREMENTS

S-parameters at 8 V, 0.6 A *

Freq(GHz)	MagS11	AngS11	MagS21	AngS21	MagS12	AngS12	MagS22	AngS22
1.00	0.83	-160.04	9.73	83.69	0.03	10.67	0.43	-161.58
2.00	0.83	172.74	5.09	56.39	0.03	-1.36	0.44	-177.86
3.00	0.82	154.96	3.52	33.76	0.03	-8.68	0.45	172.64
4.00	0.81	138.74	2.76	12.10	0.04	-15.03	0.46	163.91
5.00	0.80	121.96	2.33	-9.58	0.04	-21.71	0.46	154.62
6.00	0.78	103.30	2.09	-31.92	0.05	-29.82	0.46	144.17
7.00	0.76	81.44	1.94	-55.55	0.06	-40.40	0.46	132.05
8.00	0.73	54.99	1.85	-81.15	0.08	-54.36	0.45	117.44
9.00	0.73	23.08	1.76	-109.24	0.09	-72.30	0.43	98.87
10.00	0.75	-13.06	1.64	-139.88	0.11	-94.20	0.41	74.02

* Download S-parameters file from website: <http://www.amcomusa.com>

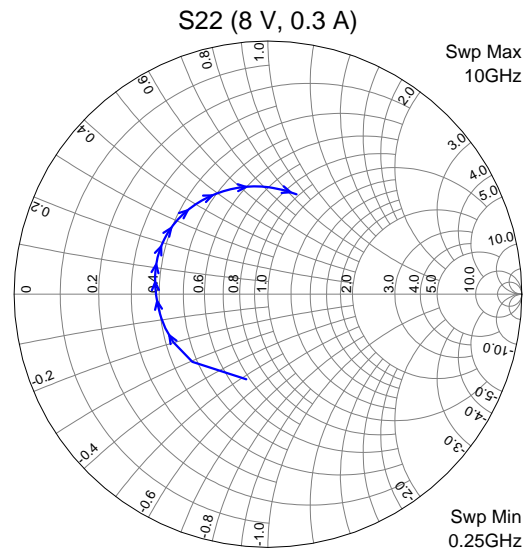
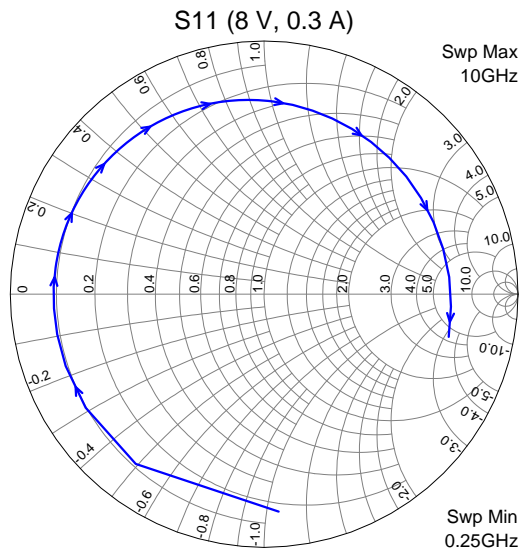
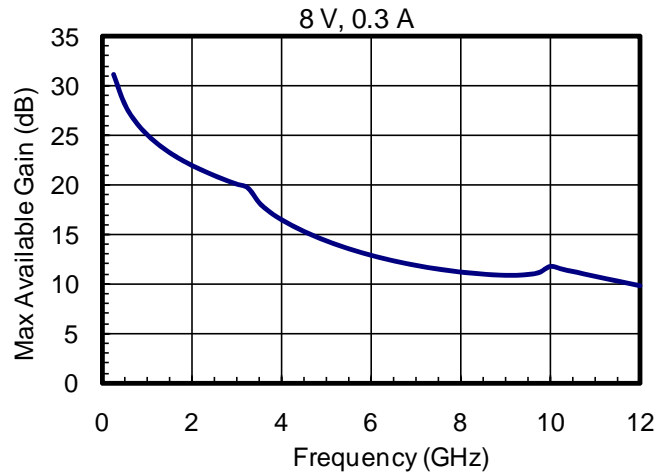
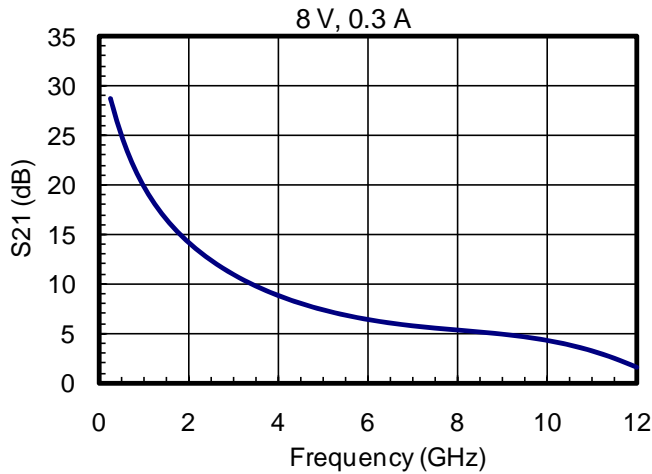

POWER DATA

Optimum Load

Freq (GHz)	MAG(Γ_L)	ANG(Γ_L)
1.00	0.61	-175.99
2.00	0.56	-162.49
3.00	0.55	-153.25
4.00	0.53	-145.13
5.00	0.52	-129.99
6.00	0.55	-113.98
7.00	0.40	-97.66
8.00	0.38	-81.70
9.00	0.36	-49.24
10.00	0.27	-26.90

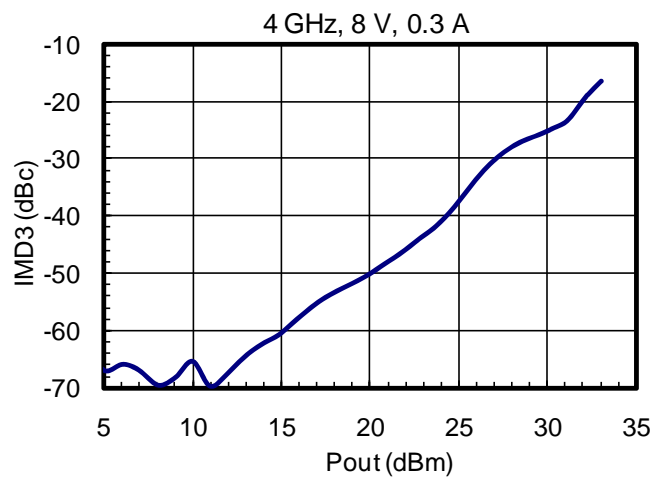
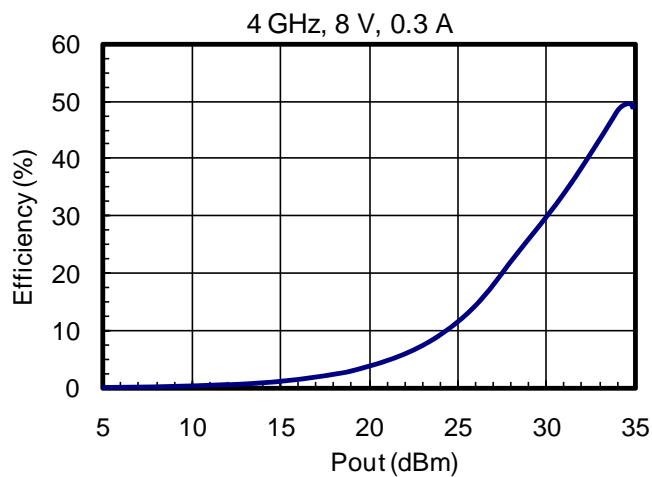
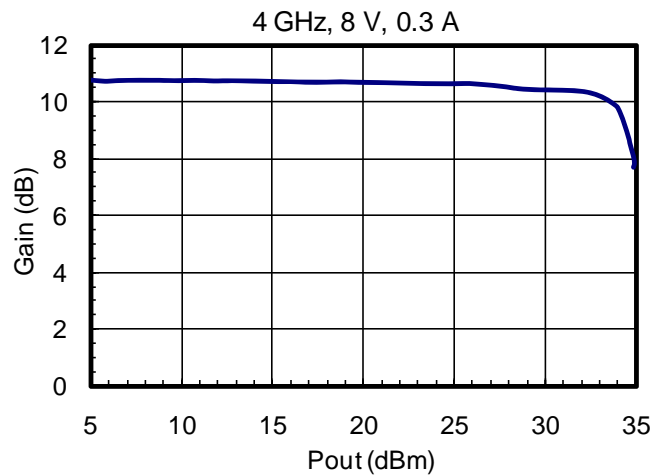
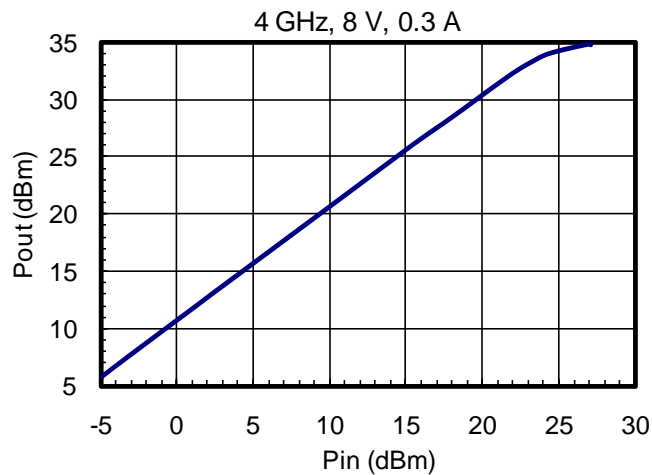
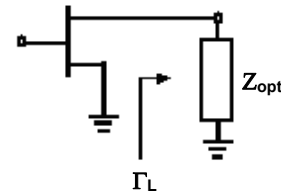

PACKAGE OUTLINE

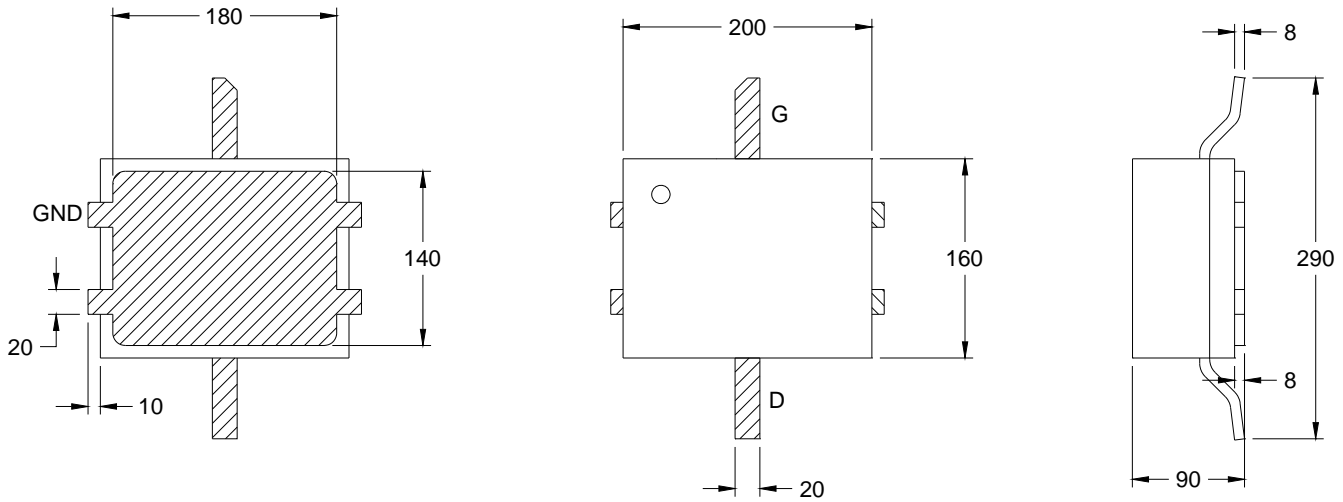

*All Dimensions are in inches

MOUNTING INSTRUCTIONS

The device may dissipate several watts of power. It is important to provide a good heat sink to dissipate the heat. There are two options of mounting the device, as shown below. The most effective way is to mount the device to a heat sink pedestal (Option 1). We strongly recommend this way for high power device. The other option, which is mounted directly on PCB, is to add sufficient number of plated through via holes to the PCB. The base of the device is soldered to the PCB (Option 2). The via hole wall should be plated by at least 1 oz thick (1.5 mil) of high thermal conductivity copper to conduct the heat from the top of PCB to the bottom of PCB. Also fill the via holes with solder to help conducting the heat.

Option 1 (Recommended)

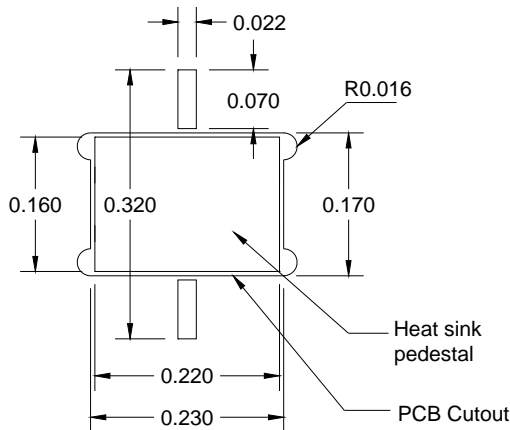

Option 2

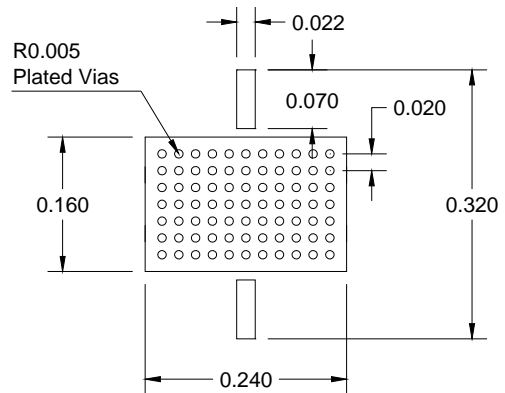

* All Dimensions are in inch