

DESCRIPTION

AMCOM's AM010WX-BH-R is a discrete GaAs pHEMT that has a total gate width of 1mm. It is in a ceramic BH package for operating up to 12GHz. The BH package has all leads bent in a surface mounting style on PC Board. The bottom of the package serves simultaneously as DC ground, RF ground, and thermal path. For frequencies above 5GHz, we recommend to mount the device directly on a metal heat sink, which is also RF ground, to avoid the inductance of PCB via holes. This part is RoHS compliant.

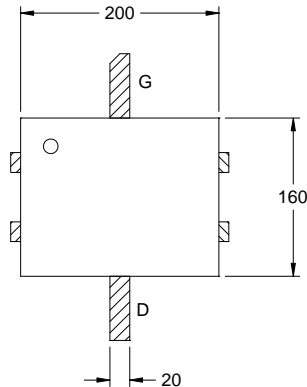

FEATURES

- High Frequency Operation up to 12GHz
- Gain=14dB, $P_{1dB}=29.8dBm$, Eff = 50% @ 4GHz
- Surface Mountable
- Bottom ground for Effective Heat Removal

APPLICATIONS

- Wireless Local Loop
- WiMAX
- Cellular Radio
- WLAN, Repeaters & HYPERLAN
- C-Band VSAT
- Radar

DC PARAMETERS

Parameters	Conditions	MIN	TYP	MAX
Drain Current I_{dss} (mA)	$V_{ds} = 3V$ $V_{gs} = 0V$	240	300	360
Pinch-off Voltage V_p (V)	$V_{ds} = 3V$ $I_{ds} = 2.5\% I_{dss}$	-1.6	-1.2	-0.8
Drain to Gate Breakdown Voltage BV_{gd} (V)	$I_{dg} = 1mA/mm$	15	20	
Thermal Resistance ($^{\circ}C/W$)		80		

RF PERFORMANCE @ 4GHz, ($V_{ds} = 8V$, $I_{ds} = 0.5 I_{dss}$)

Parameters	MIN	TYP
P_{1dB} * (dBm)	28.8	29.8
Eff @ P_{1dB}	40%	50%
Small Signal Gain (dB)	13	14
IP3 (dBm)	37	38.5

* Power typically remains similar as frequency changes.

ABSOLUTE MAXIMUM RATING

Parameters	Sym	Rating
Drain-Source Voltage (V)	V_{ds}	10
Gate-Source Voltage (V)	V_{gs}	-5
Drain Current (mA)	I_{ds}	300
Continuous Dissipation At Room Temp. (W)	P_t	1.9
Operating Temp. ($^{\circ}C$)	T_A	-55 to +85
Max. Channel Temp. ($^{\circ}C$)	T_{ch}	+175

SMALL SIGNAL MEASUREMENTS

S-Parameters for AM010WX-BH-R, Vds = 8V, Vgs = - 1V, Ids = 100mA

Frequency (Ghz)	S11 Mag	S11 Ang	S21 Mag	S21 Ang	S12 Mag	S12 Ang	S22 Mag	S22 Ang
0.1	0.950	-13.1	18.782	168.9	0.004	80.6	0.527	-7.3
0.2	0.943	-26.0	18.405	160.2	0.007	74.1	0.519	-14.3
0.3	0.931	-38.4	17.836	151.8	0.010	67.3	0.508	-21.0
0.4	0.918	-50.2	17.129	143.9	0.013	60.7	0.495	-27.3
0.5	0.904	-61.2	16.338	136.4	0.016	54.6	0.481	-33.2
0.6	0.889	-71.3	15.509	129.5	0.018	49.0	0.467	-38.6
0.7	0.875	-80.7	14.680	123.0	0.020	43.9	0.453	-43.6
0.8	0.862	-89.4	13.875	117.0	0.021	39.2	0.441	-48.2
0.9	0.850	-97.3	13.109	111.4	0.022	34.8	0.430	-52.5
1.0	0.839	-104.6	12.391	106.1	0.024	30.9	0.420	-56.4
1.5	0.798	-133.6	9.544	84.0	0.027	15.4	0.391	-73.0
2.0	0.772	-154.6	7.680	66.0	0.029	4.2	0.386	-86.4
2.5	0.750	-171.4	6.433	50.2	0.030	-4.4	0.393	-98.0
3.0	0.730	173.9	5.567	35.5	0.031	-11.5	0.406	-108.6
3.5	0.707	160.0	4.946	21.4	0.032	-17.6	0.420	-118.3
4.0	0.682	146.2	4.491	7.5	0.034	-23.1	0.435	-127.4
4.5	0.652	131.8	4.150	-6.5	0.036	-28.5	0.447	-136.0
5.0	0.619	116.2	3.889	-20.8	0.039	-34.0	0.457	-144.3
5.5	0.584	98.7	3.682	-35.5	0.042	-40.1	0.464	-152.4
6.0	0.551	78.7	3.507	-50.8	0.047	-47.1	0.466	-160.4
6.5	0.526	56.0	3.344	-66.7	0.052	-55.3	0.463	-168.5
7.0	0.517	31.0	3.178	-83.3	0.058	-64.7	0.452	-176.9
7.5	0.533	5.1	2.999	-100.5	0.064	-75.3	0.431	174.4
8.0	0.571	-19.7	2.800	-118.0	0.069	-87.0	0.396	165.3
8.5	0.627	-42.0	2.585	-135.7	0.075	-99.5	0.344	156.1
9.0	0.690	-61.6	2.357	-153.6	0.079	-112.7	0.273	147.3
9.5	0.754	-78.6	2.123	-171.5	0.082	-126.5	0.183	140.8
10.0	0.813	-93.5	1.885	170.7	0.084	-140.7	0.081	150.1
10.5	0.864	-106.6	1.649	153.0	0.084	-155.2	0.080	-116.7
11.0	0.907	-118.4	1.416	135.5	0.082	-169.8	0.207	-106.1
11.5	0.939	-129.0	1.194	118.7	0.079	175.9	0.342	-113.7
12.0	0.961	-138.6	0.990	102.7	0.073	162.2	0.468	-124.0
12.5	0.976	-147.2	0.810	87.9	0.067	149.4	0.578	-134.7
13.0	0.985	-155.0	0.657	74.4	0.061	137.7	0.668	-144.9
13.5	0.990	-162.2	0.532	62.2	0.055	127.1	0.739	-154.4
14.0	0.992	-168.7	0.431	51.2	0.050	117.4	0.795	-163.0
14.5	0.993	-174.7	0.351	41.2	0.045	108.7	0.837	-171.0
15.0	0.994	179.6	0.287	32.2	0.040	100.8	0.870	-178.2
15.5	0.994	174.2	0.237	24.0	0.036	93.5	0.894	175.2
16.0	0.994	169.1	0.198	16.5	0.033	86.8	0.914	169.0

*Download S-parameters file from website: <http://www.amcomusa.com>

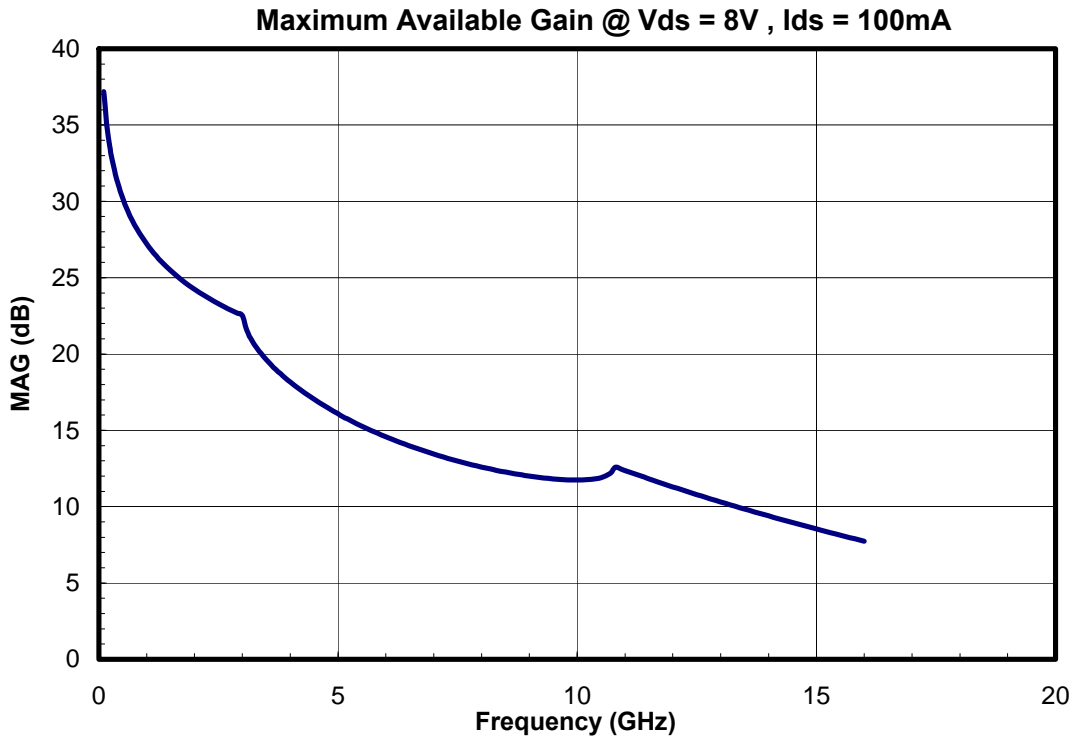

POWER MEASUREMENTS

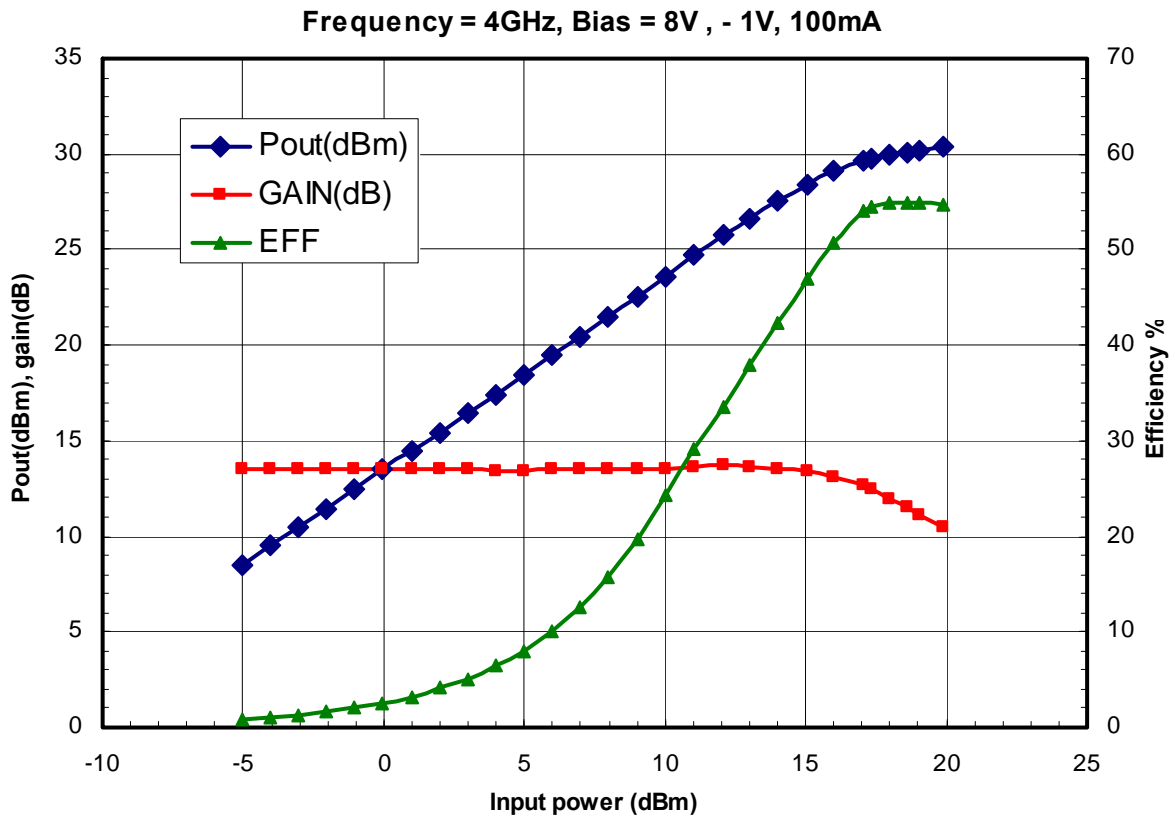

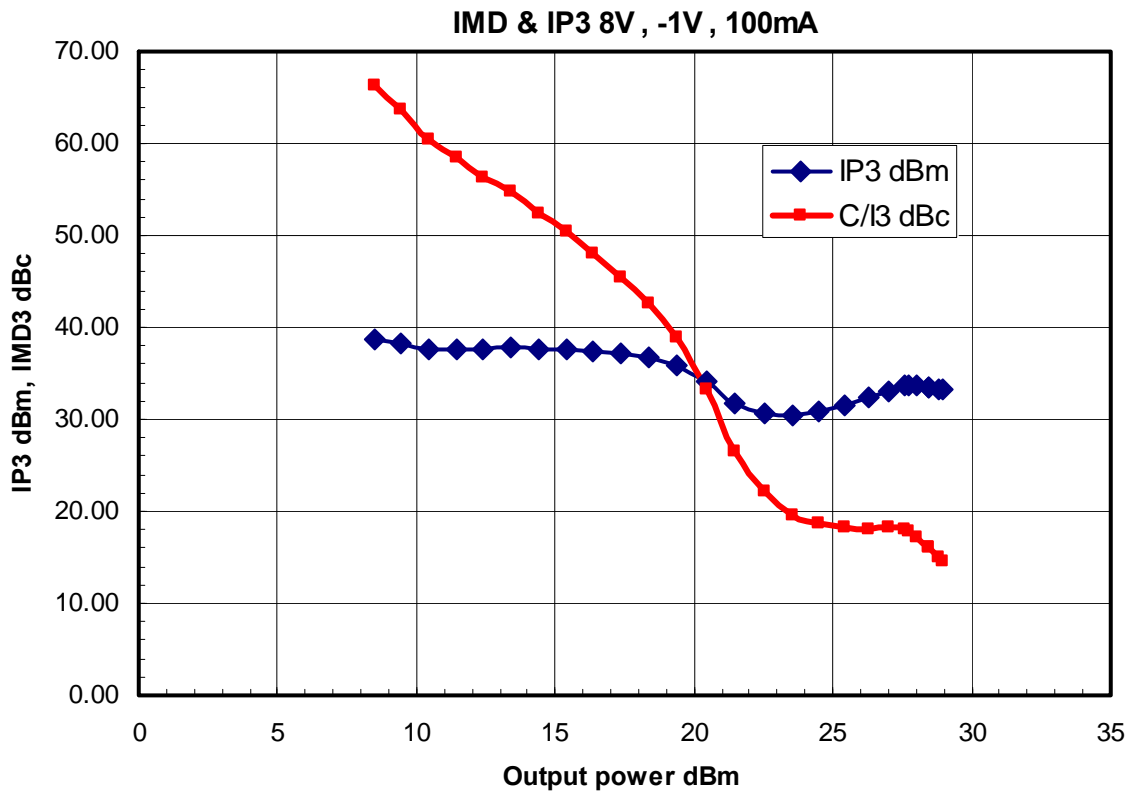

Optimal Source and Load Impedance

Freq GHz	Γ_s Real	Γ_s Imag	Γ_L Real	Γ_L Imag
4 GHz	5.8 Ohm	-j7.1 Ohm	47.1 Ohm	J0.7 Ohm

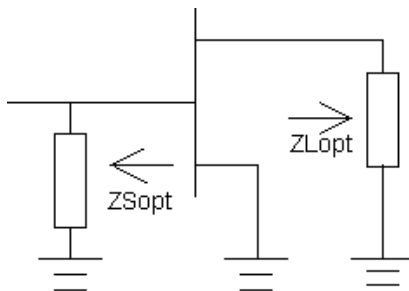

PACKAGE OUTLINE

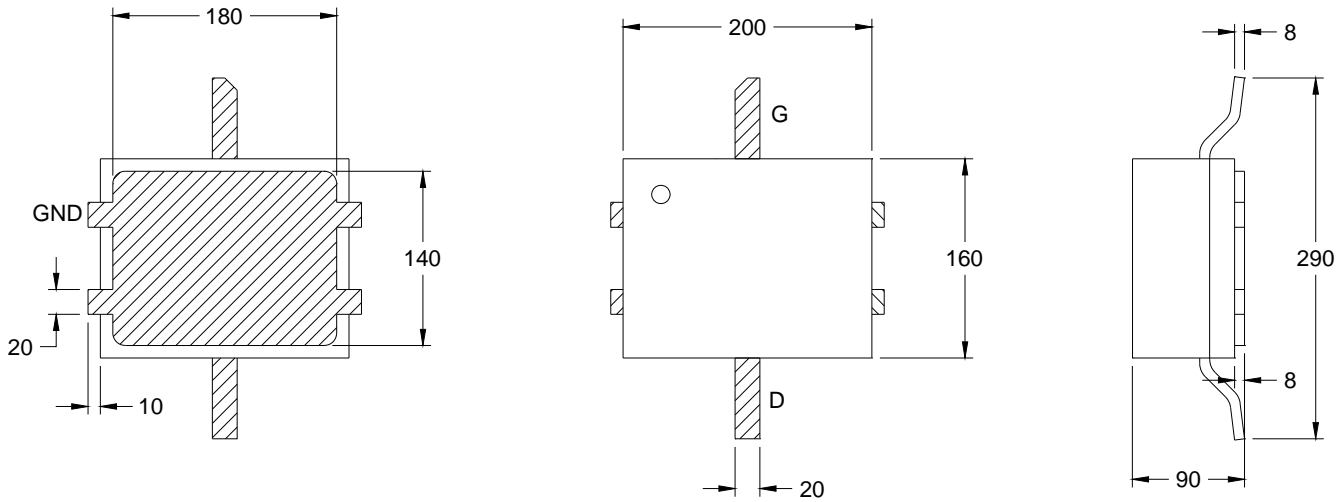

*All Dimensions are in inches

MOUNTING INSTRUCTIONS

The device may dissipate several watts of power. It is important to provide a good heat sink to dissipate the heat. There are two options of mounting the amplifier, as shown. The most effective way is to mount the amplifier to a heat sink pedestal (Option 1). We strongly recommend this way for high power device. The other option, which is mounted directly on PCB, is to add sufficient number of plated through via holes to the PCB. The base of the device is soldered to the PCB (Option 2). The via hole wall should be plated by at least 1 oz thick (1.5 mil) of high thermal conductivity copper to conduct the heat from the top of PCB to the bottom of PCB. Also fill the via holes with solder to help conducting the heat.

Option 1 (Recommended)

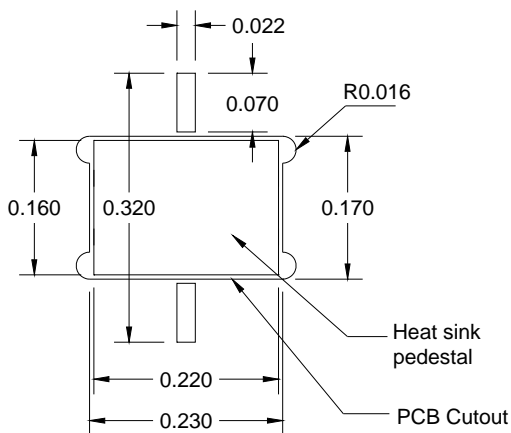

Option 2

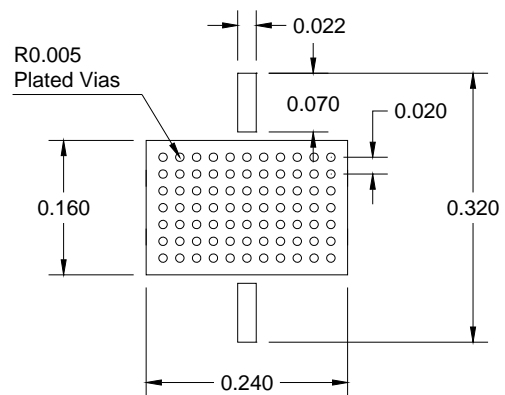

* All Dimensions are in inch