

DESCRIPTION

AMCOM's AM005WX-BH-R is a discrete GaAs pHEMT that has a total gate width of 0.5mm. It is in a ceramic BH package for operating up to 12GHz. The BH package has all leads bent in a surface mounting style on PC Board. The bottom of the package serves simultaneously as DC ground, RF ground, and thermal path. For frequencies above 5GHz, we recommend to mount the device directly on a metal heat sink, which is also RF ground, to avoid the inductance of PCB via holes. This part is RoHS compliant.

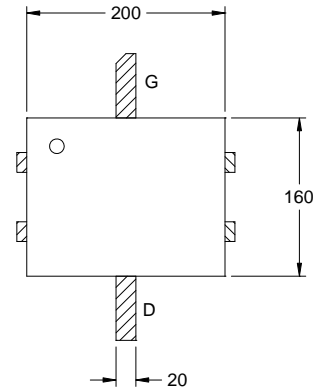

FEATURES

- High Frequency Operation up to 12GHz
- Gain=16.2dB, P_{1dB} =25.5dBm, Eff=54.8% @ 4GHz
- Surface Mountable
- Bottom ground for Effective Heat Removal

APPLICATIONS

- Wireless Local Loop
- WiMAX
- Cellular Radio
- WLAN, Repeaters & HYPERLAN
- C-Band VSAT
- Radar

DC PARAMETERS

Parameters	Conditions	MIN	TYP	MAX
Drain Current I_{dss} (mA)	$V_{ds} = 3V$ $V_{gs} = 0V$	120	150	180
Pinch-off Voltage V_p (V)	$V_{ds} = 3V$ $I_{ds} = 2.5\% I_{dss}$	-1.6	-1.2	-0.8
Drain to Gate Breakdown Voltage BV_{gd} (V)	$I_{dq} = 0.5mA$	15	20	
Thermal Resistance ($^{\circ}C/W$)		160		

RF PERFORMANCE @ 4 GHz, ($V_{ds} = 8V$, $I_{ds} = 0.5 I_{dss}$)

Parameters	MIN	TYP
P_{1dB} * (dBm)	24	25
Eff @ P_{1dB}	45%	55%
Small Signal Gain (dB)	14	16
IP3 (dBm)	35	37

* Power typically remains similar as frequency changes.

ABSOLUTE MAXIMUM RATING

Parameters	Sym	Rating
Drain-Source Voltage (V)	V_{ds}	10
Gate-Source Voltage (V)	V_{gs}	-5
Drain Current (mA)	I_{ds}	150
Continuous Dissipation At Room Temp. (W)	P_t	0.94
Operating Temp. ($^{\circ}C$)	T_A	-55 to +85
Max. Channel Temp. ($^{\circ}C$)	T_{ch}	+175

SMALL SIGNAL MEASUREMENTS

S-Parameters* @ $V_{ds} = 8V$, $V_{gs} = -1.0V$, $I_{ds} = 50mA$

GHz	S11 Mag	S11 Ang	S21 Mag	S21 Ang	S12 Mag	S12 Ang	S22 Mag	S22 Ang
0.2	0.997	-14.6	10.413	167.5	0.006	88.8	0.753	-8.7
0.3	0.983	-21.6	10.226	162.1	0.008	76.4	0.746	-12.7
0.4	0.976	-28.6	10.079	156.6	0.011	70.6	0.741	-16.8
0.5	0.968	-35.4	9.918	151.3	0.014	65.8	0.736	-20.9
1.0	0.918	-66.9	8.867	125.6	0.024	44.3	0.700	-39.8
1.5	0.853	-93.0	7.603	103.4	0.030	26.3	0.663	-56.0
2.0	0.793	-114.6	6.497	84.3	0.032	10.6	0.637	-69.9
2.5	0.750	-132.3	5.619	67.8	0.030	0.2	0.631	-81.9
3.0	0.726	-147.8	4.966	52.7	0.029	-5.7	0.640	-93.1
3.5	0.705	-161.8	4.447	38.4	0.028	-10.1	0.657	-103.2
4.0	0.685	-174.3	4.036	24.9	0.028	-12.2	0.676	-112.8
4.5	0.655	175.3	3.752	12.3	0.028	-17.1	0.688	-121.7
5.0	0.611	164.2	3.565	-0.1	0.029	-21.3	0.703	-128.9
5.5	0.554	151.6	3.444	-12.9	0.029	-24.7	0.716	-135.6
6.0	0.483	135.8	3.361	-26.6	0.031	-29.1	0.729	-142.2
6.5	0.404	115.0	3.282	-41.2	0.033	-35.5	0.736	-149.1
7.0	0.338	86.5	3.185	-56.8	0.035	-44.4	0.738	-156.3
7.5	0.307	51.6	3.059	-72.9	0.038	-54.8	0.733	-163.8
8.0	0.320	16.9	2.911	-89.2	0.040	-66.2	0.718	-171.9
8.5	0.360	-13.5	2.762	-105.6	0.041	-77.9	0.698	179.7
9.0	0.414	-40.1	2.607	-122.0	0.044	-89.2	0.669	170.7
9.5	0.484	-62.9	2.453	-138.5	0.046	-99.6	0.638	161.5
10.0	0.559	-82.7	2.292	-154.9	0.050	-110.7	0.606	152.3
10.5	0.633	-99.4	2.135	-171.1	0.054	-122.2	0.571	143.0
11.0	0.693	-114.8	1.979	172.9	0.059	-134.0	0.531	133.9
11.5	0.741	-129.3	1.826	156.9	0.062	-145.2	0.481	125.6
12.0	0.780	-142.6	1.679	141.1	0.064	-156.0	0.422	118.8
12.5	0.815	-154.8	1.531	125.2	0.066	-166.3	0.353	115.1
13.0	0.847	-165.8	1.388	109.5	0.067	-176.4	0.279	117.3
13.5	0.873	-176.0	1.245	92.5	0.065	173.8	0.224	130.5
14.0	0.892	174.5	1.091	74.7	0.061	164.5	0.234	151.6
14.5	0.907	166.3	0.926	56.4	0.053	156.6	0.318	161.2
15.0	0.913	159.9	0.762	38.3	0.043	154.1	0.427	158.1
15.5	0.911	155.5	0.610	21.0	0.034	163.0	0.533	149.2
16.0	0.896	152.4	0.481	4.6	0.035	-178.1	0.633	139.3

* Download S-parameters file from website: <http://www.amcomusa.com>

Maximum Available Gain

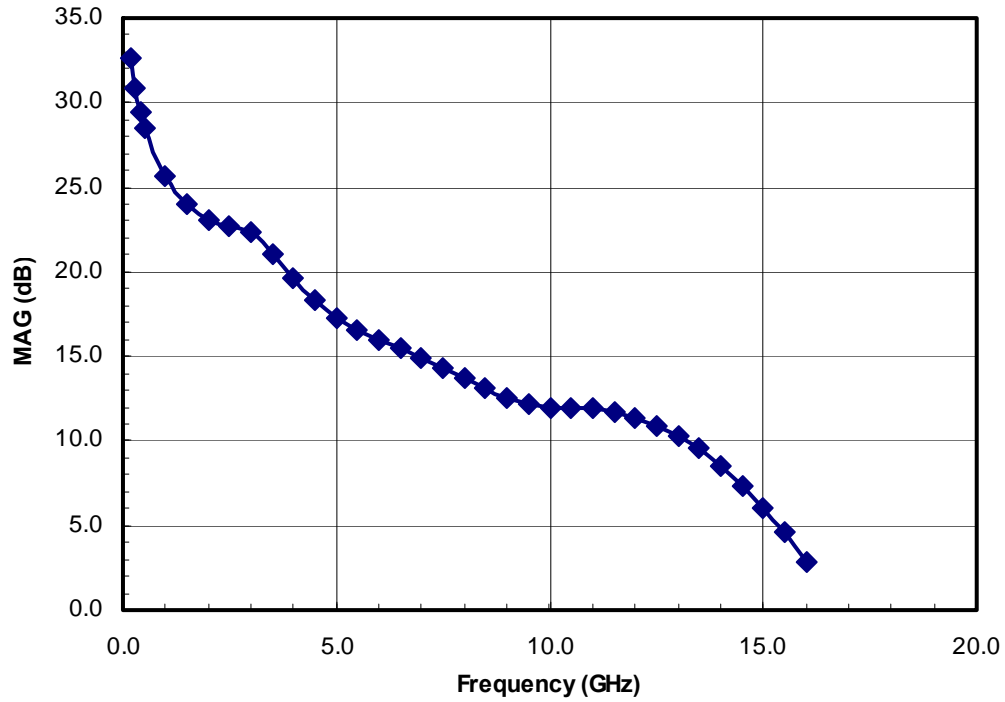

POWER MEASUREMENTS

Pout @ Frequency = 4GHz, Bias = 8V / - 0.8V

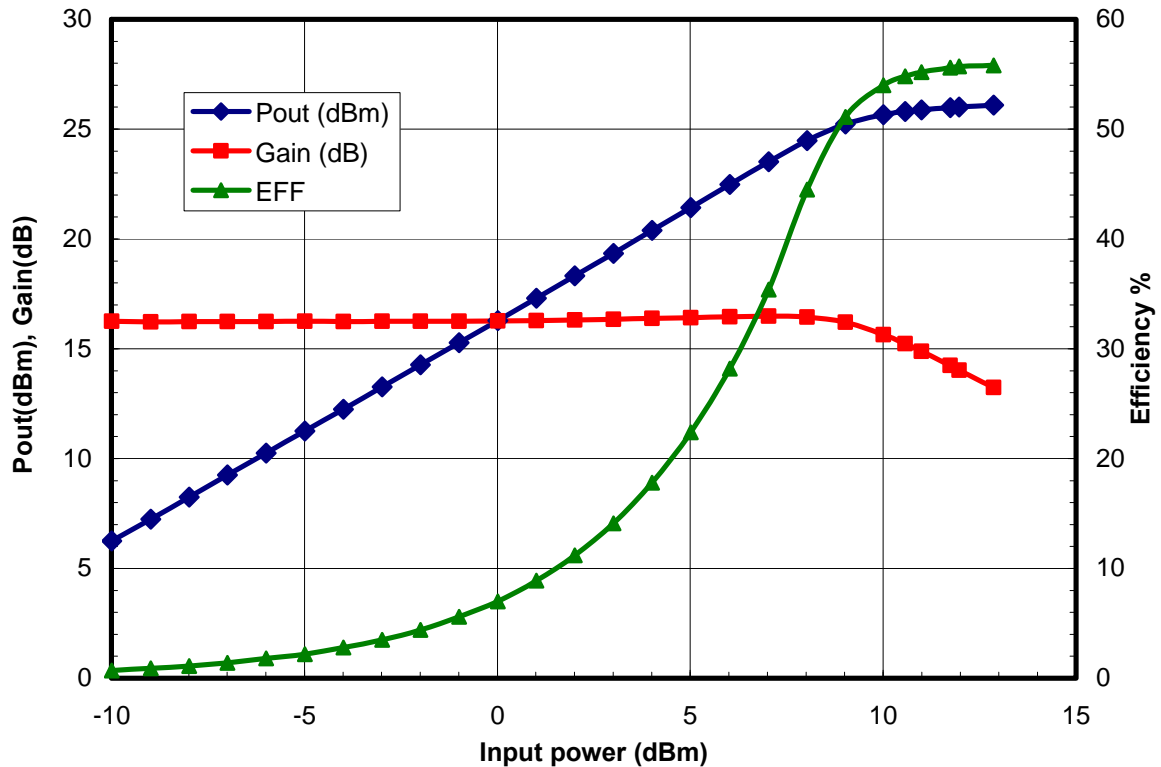

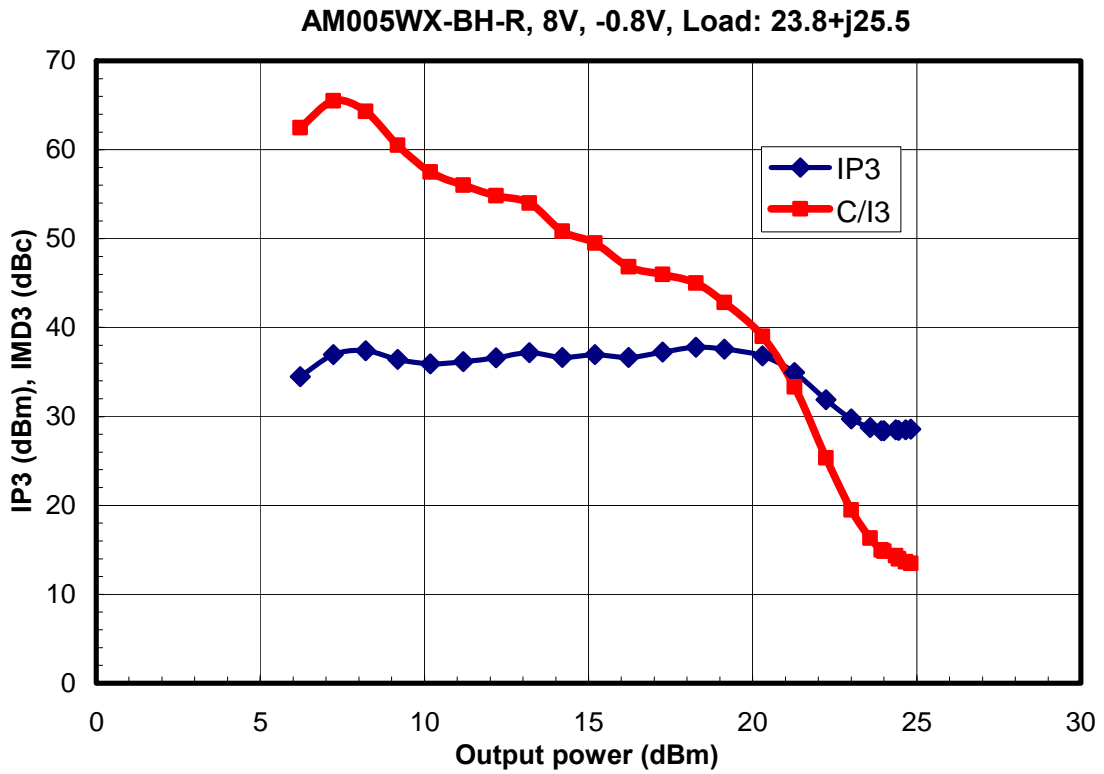

Optimal Source and Load Impedances

Frequency (GHz)	Re(Γ_s)	Im(Γ_s)	Re(Γ_L)	Im(Γ_L)
4 GHz	6.3 Ohm	j25 Ohm	23.8 Ohm	j25.5 Ohm

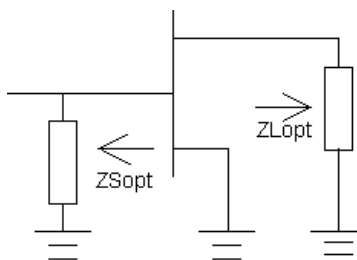

PACKAGE OUTLINE

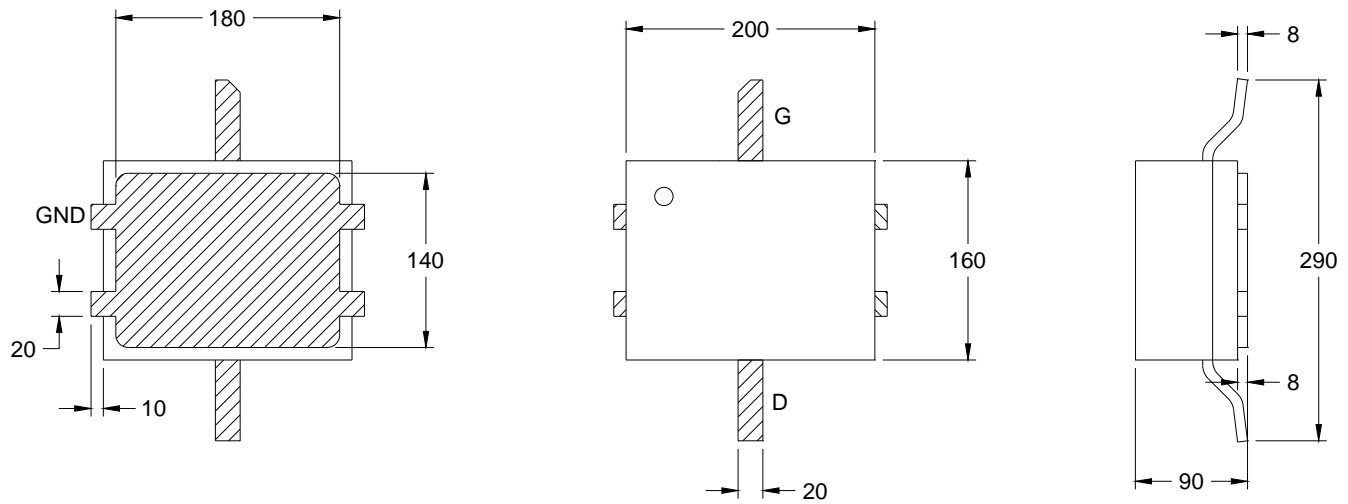

*All Dimensions are in inches

MOUNTING INSTRUCTIONS

The device may dissipate several watts of power. It is important to provide a good heat sink to dissipate the heat. There are two options of mounting the amplifier, as shown. The most effective way is to mount the amplifier to a heat sink pedestal (Option 1). We strongly recommend this way for high power device. The other option, which is mounted directly on PCB, is to add sufficient number of plated through via holes to the PCB. The base of the device is soldered to the PCB (Option 2). The via hole wall should be plated by at least 1 oz thick (1.5 mil) of high thermal conductivity copper to conduct the heat from the top of PCB to the bottom of PCB. Also fill the via holes with solder to help conducting the heat.

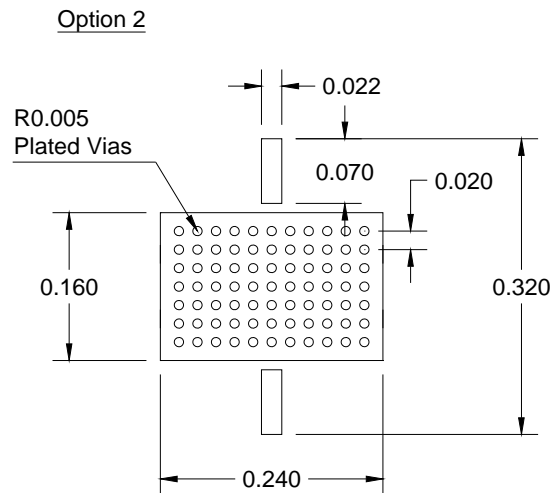
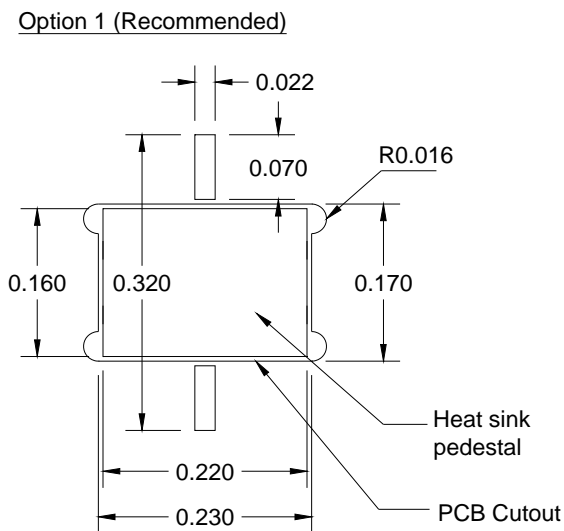

* All Dimensions are in inch